



ENAPART



93 S Railroad Avenue Unit C
Bergenfield NJ 07621 USA
www.enapart.com
sales@enapart.com



Via del Canneto 35,
Borgosatollo, Brescia - Italia
www.enapart.it
vendite@enapart.it



Barbaros Mah. Ihlamur Bul. Aĝaoĝlu
My Newwork No:3/15 Ataşehir / İstanbul
www.enapart.net
satis@enapart.net



PRIVADA 10 B SUR #3908 COL.
ANZUREZ, C.P. 72530, PUEBLA, PUE
www.enapart.com.mx
sales@enapart.com.mx



Friedrich-Ebert-Anlage 36, 60325
Frankfurt am Main, Germany
www.enapart.de
anfrage@enapart.de



4 boulevard Carnot, 95400
villiers-le-bel, Paris, France
www.enapart.fr
sales@enapart.fr



65049, ОДЕСА, ВУЛИЦЯ ІВАНА
ФРАНКА, БУДИНОК 55, ПОВЕРХ 3
www.enapart.com.ua
sales@enapart.com.ua



MUNICIPIUL BUCUREȘTI, SECTOR 3,
B-DUL BASARABIA, NR.250, CORP P+5
www.enapart.ro
sales@enapart.ro



〒584-0023 大阪府富田林市若松町
東2丁目2番16号
www.enapart.co.jp
sales@enapart.co.jp



PLAZA NUESTRA SEÑORA DE LAS
NIEVES 12 ,LOCAL ,50012,ZARAGOZA
www.enapart.es
ventas@enapart.es



Складова база „Онгъл“, Склад А2, п.к.
4006, гр. Пловдив, България
www.enapart.bg
sales@enapart.bg



3 Austin Mews, High Street, Hemel
Hempstead, HP1 3AF , United Kingdom
www.enapart.co.uk
sales@enapart.co.uk

HYDRAULIC FILTRATION PRODUCTS

SUCTION FILTERS



PASSION TO PERFORM





A WORLDWIDE LEADER IN THE FIELD OF HYDRAULIC FILTRATION EQUIPMENT.

Our company started life in 1964, when Bruno Pasotto decided to attempt to cater for the requests of a market still to be fully explored, with the study, design, development, production and marketing of a vast range of filters for hydraulic equipment, capable of satisfying the needs of manufacturers in all sectors. The quality of our products, our extreme competitiveness compared with major international producers and our constant activities of research, design and development has made us a worldwide leader in the field of hydraulic circuit filtering. Present for 50 years in the market, we have played a truly decisive role in defining our sector, and by now we are a group capable of controlling our entire chain of production, monitoring all manufacturing processes to guarantee superior quality standards and to provide concrete solutions for the rapidly evolving needs of customers and the market.

MARKET LEADER



Our work is based on a skillful interaction between advanced technology and fine workmanship, **customizing products according to specific market requests**, focusing strongly on innovation and quality, and following every step in the manufacturing of both standard and special products, fully respecting customer expectations.



Our customer-oriented philosophy, which enables us to satisfy all customer requests **rapidly and with personalized products**, makes us a **dynamic and flexible enterprise**. The possibility of constantly controlling and monitoring the entire production process is essential to allow us to guarantee the quality of our products.

WORLDWIDE PRESENCE

Our foreign Branches enable us to offer a diversified range of products that allow us to successfully face the aggressive challenge of international competition, and also to maintain a stable presence at a local level.

The Group boasts **8 business branches**



TECHNOLOGY

Our constant **quest for excellence in quality and technological innovation** allows us to offer only the best solutions and services for applications in many fields, including general industry, test rigs, lubrication, heavy engineering, renewable energies, naval engineering, offshore engineering, aviation systems, emerging technologies and mobile plant (i.e. tractors, excavators, concrete pumps, platforms).



AND PRODUCTION

Our high level of technological expertise means **we can rely entirely on our own resources, without resorting to external providers.** This in turn enables us to satisfy a growing number of customer requests, also exploiting our constantly updated range of machines and equipment, featuring **fully-automated workstations** capable of **24-hour production.**

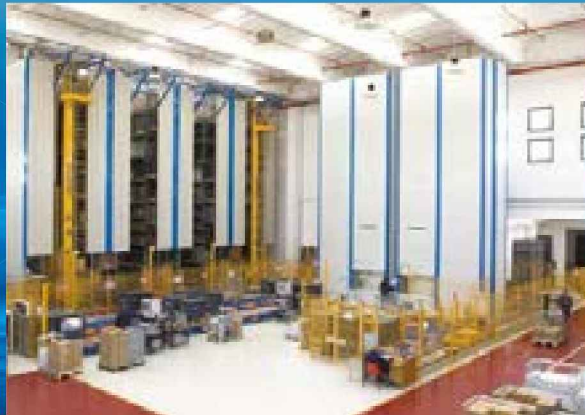



SUCTION FILTERS

Flow rates up to 875 l/min

- Mounting:
- Tank immersed
 - In-Line
 - In tank with shut off valve
 - In tank with flooded suction

RETURN FILTERS

Flow rates up to 3000 l/min

- Pressure up to 20 bar
- Mounting:
- In-Line
 - Tank top
 - In single and duplex designs

RETURN / SUCTION FILTERS

Flow rates up to 300 l/min

- Pressure up to 80 bar
- Mounting:
- In-Line
 - Tank top

SPIN-ON FILTERS

Flow rates up to 365 l/min

- Pressure up to 35 bar
- Mounting:
- In-Line
 - Tank top

LOW & MEDIUM PRESSURE FILTERS

Flow rates up to 3000 l/min

- Pressure up to 80 bar
- Mounting:
- In-Line
 - Parallel manifold version
 - In single and duplex designs

HIGH PRESSURE FILTERS

Flow rates up to 750 l/min

- Pressure from 110 bar up to 560 bar
- Mounting:
- In-Line
 - Manifold
 - In single and duplex designs

PRODUCT RANGE

MP Filtri can offer a vast and articulated range of products for the global market, suitable for all industrial sectors using hydraulic equipment. This includes filters (suction, in-line, pressure, stainless steel, spin-on and return) and structural components (motor/pump bell housings, transmission couplings, flexible inserts, damper rings, support feet, aluminium tanks, inspection hatches).

We can provide all the skills and solutions required by the modern hydraulics industry to monitor contamination levels and other fluid conditions.

Mobile filtration units and a full range of accessories allow us to supply everything necessary for complete hydraulic circuits.



STAINLESS STEEL HIGH PRESSURE FILTERS

Flow rates up to 125 l/min
Pressure from 320 bar up to 1000 bar

- Mounting:
- In-Line
 - Manifold
 - In single and duplex designs

CONTAMINATION MONITORING PRODUCTS

- Calibrated on test rigs manufactured and certified to ISO 11943 based on methods from ISO 11171
- Off-line and In-line particles counting up to 400 bar
- Bottle samplers
- RS 232 - RS 485 digital bus interfaces

MOBILE FILTRATION UNITS

Flow rates from 15 l/min up to 200 l/min

POWER TRANSMISSION PRODUCTS

- Aluminium bell-housings for motors from 0.12 kW to 400 kW
- Couplings in Aluminium Cast Iron - Steel
- Damping rings
- Foot bracket
- Aluminium tanks
- Cleaning covers

ACCESSORIES

- Oil filler and air breather plugs
- Optical and electrical level gauges
- Pressure gauge valve selectors
- Pipe fixing brackets
- Pressure gauges

HYDRAULIC FILTRATION PRODUCTS

1 page		INTRODUCTION
1	COMPANY	
6	PRODUCT RANGE	
11	CONTAMINATION MANAGEMENT	
20	FILTER SIZING	
20	CORRECTIVE FACTOR	

24 page		SUCTION FILTERS	up to Q_{max}	
			l/min	gpm
27	STR - MPA - MPM	Submerged suction filter, with bypass or magnetic column	875	231
35	SF2 250 - 350	Semi-submerged positive head suction filter	160	43
43	SF2 500	Semi-submerged positive head suction filter	800	211
53	CLOGGING INDICATORS			

56 page		RETURN FILTERS	up to P_{max}		up to Q_{max}	
			bar	psi	l/min	gpm
59	MPFX	Tank top semi-immersed filter, standard filter element disassembly	8	116	750	198
87	MPTX	Tank top semi-immersed filter, easy filter element disassembly	8	116	300	80
105	MFBX	Bowl assembly fully immersed filter			500	132
111	MPF	Tank top semi-immersed filter, standard filter element disassembly	8	116	750	198
139	MPT	Tank top semi-immersed filter, easy filter element disassembly	8	116	300	80
157	MFB	Bowl assembly fully immersed filter			500	132
163	MPH - MPI	Tank top semi-immersed filter with internal / external oil flow	10	145	3000	792
193	FRI	Tank top semi-immersed filter, easy filter element disassembly, it can be used also as in-line filter	20	290	1500	397
207	RF2	Semi-immersed under-head filter, easy filter element disassembly	20	290	350	92
214	CLOGGING INDICATORS					
224	ACCESSORIES					

226 page		RETURN / SUCTION FILTERS	up to P_{max}		up to Q_{max}	
			bar	psi	l/min	gpm
229	MRSX	Unique TANK TOP filter for mobile machinery, with combined filtration on return and suction to the inlet at the hydrostatic transmissions in closed circuit.	10	145	300	80
239	LMP 124 MULTIPORT	Unique IN-LINE filter for mobile machinery, with combined filtration on return and suction to the inlet at the hydrostatic transmissions in closed circuit.	80	1160	200	52
245	CLOGGING INDICATORS					

258 page		SPIN-ON FILTERS	up to P_{max}		up to Q_{max}	
			bar	psi	l/min	gpm
261	MPS	Low pressure filter, available with single cartridge for in-line or flange mounting or with two cartridge on the same axis on the opposite sides	12	300	365	96
277	MSH	In-line low and medium pressure filter available with single cartridge	35	508	195	52
285	MST	Low pressure tank mounted filter	12	300	195	52
291	CLOGGING INDICATORS					

302 page	LOW & MEDIUM PRESSURE FILTERS	up to P _{max}		up to Q _{max}		
		bar	psi	l/min	gpm	
305	LMP MULTIPOINT 110 - 120 - 123	In-line filter with Multiport design for multiple choice connection	80	1160	200	53
321	LMP 210 - 211	In-line low & medium pressure filter	60	870	330	87
331	LMP 400 - 401 - 430 - 431	In-line low & medium pressure filter	60	870	740	195
343	LMP 900 - 901	In-line low pressure filter, filter elements designed according to DIN 24550	30	435	2000	528
351	LMP 902 - 903	In-line filter specifically designed to be mounted in series, filter elements designed according to DIN 24550	20	290	3000	792
359	LMP 950 - 951	In-line modular filter, available with 2 and up to 6 different heads	30-25	435-362	2400	634
367	LMP 952 - 953 - 954	In-line low pressure filter specifically designed to be mounted in series	25	362	3000	792
379	LMD 211	In-line duplex medium pressure filter	60	870	330	88
387	LMD 400 - 401 - 431	In-line duplex low pressure filter	16	232	590	156
401	LMD 951	In-line duplex modular filter, available with 2 up to 6 different heads	16-25	232-362	1200	315
409	LDP - LDD	In-line and duplex medium pressure filter, filter elements designed according to DIN 24550	60	870	330	88
418	CLOGGING INDICATORS					

424 page	HIGH PRESSURE FILTERS	up to P _{max}		up to Q _{max}		
		bar	psi	l/min	gpm	
427	FMP 039	Versatile filter for high pressure - low flow rate applications	110	1595	80	21
435	FMP	Versatile filter for high pressure - high flow rate applications	320	4641	475	125
445	FHP	Typical high pressure filter for mobile applications	420	6091	750	198
459	FMM 050	FMM 050: Typical high pressure filter for mobile applications	420	6091	150	40
	FHA 051	FHA 051: Filter optimized for use in high pressure operating systems	560	8122	140	37
467	FHM	High pressure filter with intermediate plate construction	320	4641	450	119
483	FHB	High pressure for block mounting	320	4641	485	128
495	FHF 325	In-line manifold top mounting	350	5076	500	133
505	FHD	In-line duplex high pressure filter	350	5076	345	92
516	CLOGGING INDICATORS					

522 page	STAINLESS STEEL HIGH PRESSURE FILTERS	up to P _{max}		up to Q _{max}		
		bar	psi	l/min	gpm	
525	FZP	In-line pressure filter with threaded mount	420	6091	150	40
535	FZH	In-line pressure filter with threaded mount for higher pressure	700	10152	50	13
543	FZX	In-line pressure filter with threaded mount up to 1000 bar	1000	14504	10	2.6
551	FZB	Manifold side mounting	320	4641	75	20
559	FZM	Manifold top mounting	320	4641	70	18
567	FZD	Duplex pressure filter for continuous operation requirements	350	5076	90	24
577	CLOGGING INDICATORS					

580 page	CLOGGING INDICATORS
585	QUICK REFERENCE GUIDE

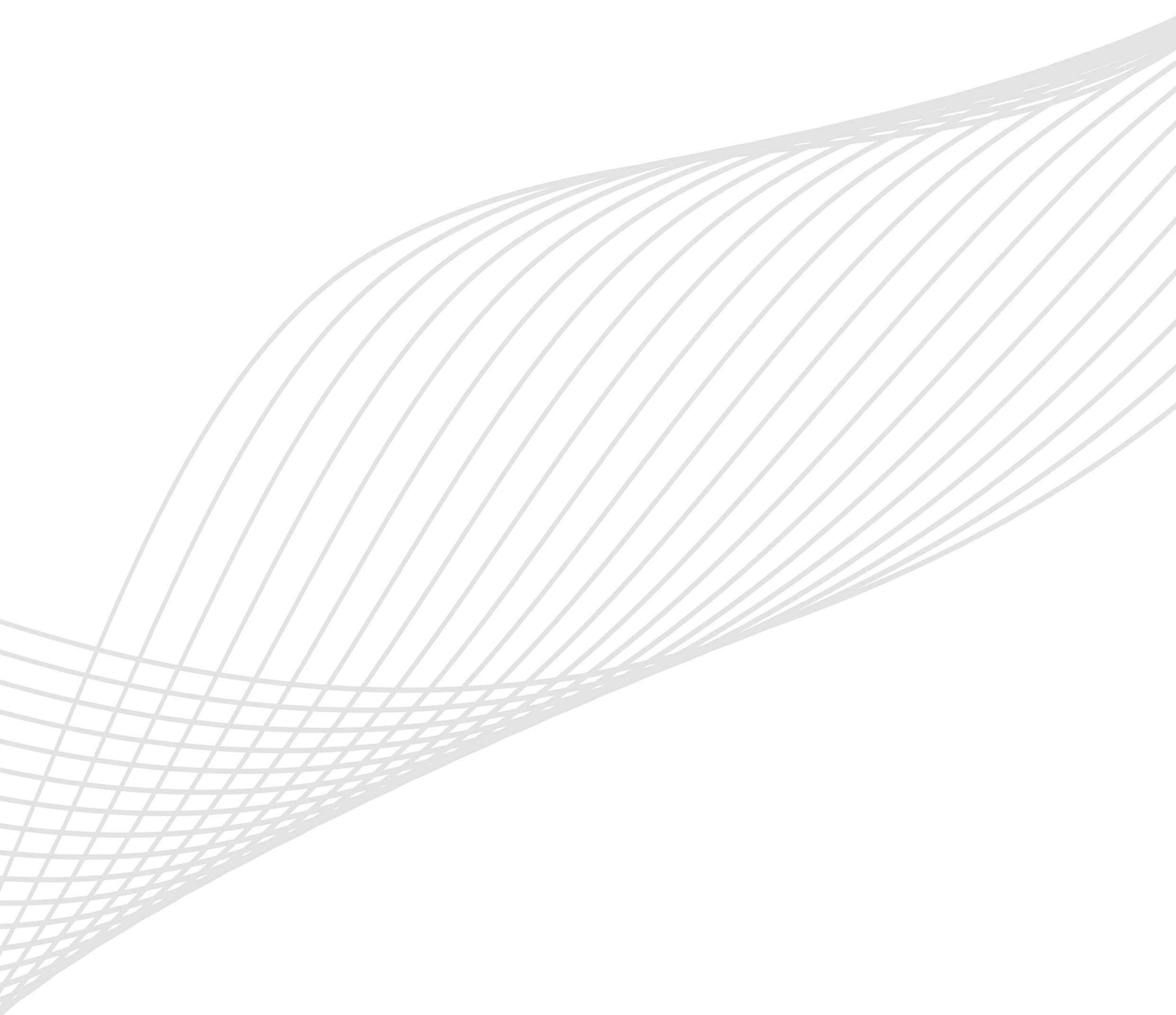

Contamination management

INDEX

	Page
① HYDRAULIC FLUIDS	12
② FLUIDS CONTAMINATION	12
③ EFFECTS OF CONTAMINATION ON HYDRAULIC COMPONENTS	12
④ MEASURING THE SOLID CONTAMINATION LEVEL	13
⑤ FILTRATION TECHNOLOGIES	16
⑥ RECOMMENDED CONTAMINATION CLASSES & FILTER TYPES	17
⑦ FILTER SIZING PARAMETERS	18
⑧ APPLICABLE STANDARDS FOR FILTER DEVELOPMENT	18

① HYDRAULIC FLUIDS

The fluid is the vector that transmits power, energy within an oleodynamic circuit. In addition to transmitting energy through the circuit, it also performs additional functions such as lubrication, protection and cooling of the surfaces.

The classification of fluids used in hydraulic systems is coded in many regulatory references, different Standards.

The most popular classification criterion divides them into the following families:

- MINERAL OILS

Commonly used oil deriving fluids.

- FIRE RESISTANT FLUIDS

Fluids with intrinsic characteristics of incombustibility or high flash point.

- SYNTHETIC FLUIDS

Modified chemical products to obtain specific optimized features.

- ECOLOGICAL FLUIDS

Synthetic or vegetable origin fluids with high biodegradability characteristics.

The choice of fluid for an hydraulic system must take into account several parameters.

These parameters can adversely affect the performance of an hydraulic system, causing delay in the controls, pump cavitation, excessive absorption, excessive temperature rise, efficiency reduction, increased drainage, wear, jam/block or air intake in the plant.

The main properties that characterize hydraulic fluids and affect their choice are:

- DYNAMIC VISCOSITY

It identifies the fluid's resistance to sliding due to the impact of the particles forming it.

- CINEMATIC VISCOSITY

It is a widespread formal dimension in the hydraulic field.

It is calculated with the ratio between the dynamic viscosity and the fluid density.

Cinematic viscosity varies with temperature and pressure variations.

- VISCOSITY INDEX

This value expresses the ability of a fluid to maintain viscosity when the temperature changes.

A high viscosity index indicates the fluid's ability to limit viscosity variations by varying the temperature.

- FILTERABILITY INDEX

It is the value that indicates the ability of a fluid to cross the filter materials. A low filterability index could cause premature clogging of the filter material.

- WORKING TEMPERATURE

Working temperature affects the fundamental characteristics of the fluid. As already seen, some fluid characteristics, such as cinematic viscosity, vary with the temperature variation.

When choosing a hydraulic oil, must therefore be taken into account of the environmental conditions in which the machine will operate.

- COMPRESSIBILITY MODULE

Every fluid subjected to a pressure contracts, increasing its density.

The compressibility module identifies the increase in pressure required to cause a corresponding increase in density.

- HYDROLYTIC STABILITY

It is the characteristic that prevents galvanic pairs that can cause wear in the plant/system.

- ANTIOXIDANT STABILITY AND WEAR PROTECTION

These features translate into the capacity of a hydraulic oil to avoid corrosion of metal elements inside the system.

- HEAT TRANSFER CAPACITY

It is the characteristic that indicates the capacity of hydraulic oil to exchange heat with the surfaces and then cool them.

② FLUID CONTAMINATION

Whatever the nature and properties of fluids, they are inevitably subject to contamination. Fluid contamination can have two origins:

- INITIAL CONTAMINATION

Caused by the introduction of contaminated fluid into the circuit, or by incorrect storage, transport or transfer operations.

- PROGRESSIVE CONTAMINATION

Caused by factors related to the operation of the system, such as metal surface wear, sealing wear, oxidation or degradation of the fluid, the introduction of contaminants during maintenance, corrosion due to chemical or electrochemical action between fluid and components, cavitation. The contamination of hydraulic systems can be of different nature:

- SOLID CONTAMINATION

For example rust, slag, metal particles, fibers, rubber particles, paint particles or additives

- LIQUID CONTAMINATION

For example, the presence of water due to condensation or external infiltration or acids

- GASEOUS CONTAMINATION

For example, the presence of air due to inadequate oil level in the tank, drainage in suction ducts, incorrect sizing of tubes or tanks.

③ EFFECTS OF CONTAMINATION ON HYDRAULIC COMPONENTS

Solid contamination is recognized as the main cause of malfunction, failure and early degradation in hydraulic systems. It is impossible to delete it completely, but it can be effectively controlled by appropriate devices.

CONTAMINATION IN PRESENCE OF
LARGE TOLERANCES



CONTAMINATION IN PRESENCE OF
NARROW TOLERANCES



Solid contamination mainly causes surface damage and component wear.

- ABRASION OF SURFACES

Cause of leakage through mechanical seals, reduction of system performance, failures.

- SURFACE EROSION
Cause of leakage through mechanical seals, reduction of system performance, variation in adjustment of control components, failures.
- ADHESION OF MOVING PARTS
Cause of failure due to lack of lubrication.
- DAMAGES DUE TO FATIGUE
Cause of breakdowns and components breakdown.stem performance, failures.
- SURFACE EROSION
Cause of leakage through mechanical seals, reduction of system performance, variation in adjustment of control components, failures.
- ADHESION OF MOVING PARTS
Cause of failure due to lack of lubrication.
- DAMAGES DUE TO FATIGUE
Cause of breakdowns and components breakdown.

Gaseous contamination mainly results in decay of system performance.

- CUSHION SUSPENSION
Cause of increased noise and cavitation.
- FLUID OXIDATION
Cause of corrosion acceleration of metal parts.
- MODIFICATION OF FLUID PROPERTIES (COMPRESSIBILITY MODULE, DENSITY, VISCOSITY)
Cause of system's reduction of efficiency and of controllability. It is easy to understand how a system without proper contamination management is subject to higher costs than a system that is provided.
- MAINTENANCE
Maintenance activities, spare parts, machine stop costs
- ENERGY AND EFFICIENCY
Efficiency and performance reduction due to friction, drainage, cavitation.

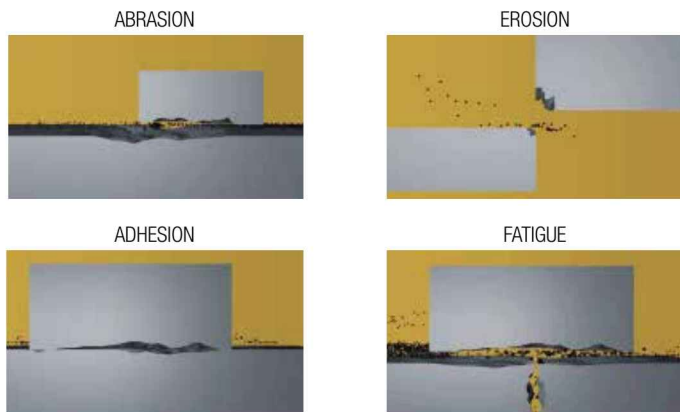

Liquid contamination mainly results in decay of lubrication performance and protection of fluid surfaces.

DISSOLVED WATER

- INCREASING FLUID ACIDITY
Cause of surface corrosion and premature fluid oxidation
- GALVANIC COUPLE AT HIGH TEMPERATURES
Cause of corrosion

FREE WATER - ADDITIONAL EFFECTS

- DECAY OF LUBRICANT PERFORMANCE
Cause of rust and sludge formation, metal corrosion and increased solid contamination
- BATTERY COLONY CREATION
Cause of worsening in the filterability feature
- ICE CREATION AT LOW TEMPERATURES
Cause damage to the surface
- ADDITIVE DEPLETION
Free water retains polar additives

4 MEASURING THE SOLID CONTAMINATION LEVEL

The level of contamination of a system identifies the amount of contaminant contained in a fluid.

This parameter refers to a unit volume of fluid.

The level of contamination may be different at different points in the system. From the information in the previous paragraphs it is also apparent that the level of contamination is heavily influenced by the working conditions of the system, by its working years and by the environmental conditions.

What is the size of the contaminating particles that we must handle in our hydraulic circuit?



HUMAN HAIR
(75 μm)

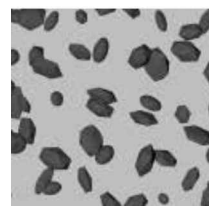

MINIMUM DIMENSION
VISIBLE HUMAN EYES
(40 μm)

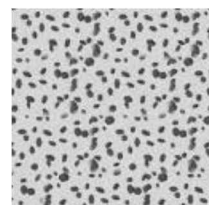

TYPICAL CONTAMINANT
DIMENSION IN A
HYDRAULIC CIRCUIT
(4÷14 μm)

Contamination level analysis is significant only if performed with a uniform and repeatable method, conducted with standard test methods and suitably calibrated equipment.

To this end, ISO has issued a set of standards that allowa to conduct tests and express the measured values in the following ways.

CONTAMINATION MANAGEMENT

- GRAVIMETRIC LEVEL - ISO 4405

The level of contamination is defined by checking the weight of particles collected by a laboratory membrane. The membrane must be cleaned, dried and desiccated, with fluid and conditions defined by the Standard.

The volume of fluid is filtered through the membrane by using a suitable suction system. The weight of the contaminant is determined by checking the weight of the membrane before and after the fluid filtration.

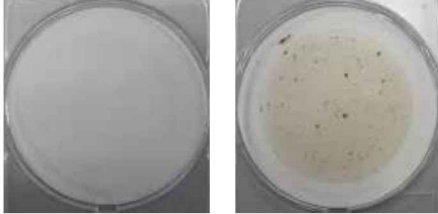

- CUMULATIVE DISTRIBUTION OF THE PARTICLES SIZE - ISO 4406

The level of contamination is defined by counting the number of particles of certain dimensions per unit of volume of fluid. Measurement is performed by Automatic Particle Counters (APC).

Following the count, the contamination classes are determined, corresponding to the number of particles detected in the unit of fluid.

The most common classification methods follow ISO 4406 and SAE AS 4059 (Aerospace Sector) regulations.

NAS 1638 is still used although obsolete.

Classification example according to ISO 4406

The code refers to the number of particles of the same size or greater than 4, 6 or 14 μm in a 1 ml fluid.

Class	Number of particles per ml	
	Over	Up to
28	1 300 000	2 500 000
27	640 000	1 300 000
26	320 000	640 000
25	160 000	320 000
24	80 000	160 000
23	40 000	80 000
22	20 000	40 000
21	10 000	20 000
20	5 000	10 000
19	2 500	5 000
18	1 300	2 500
17	640	1 300
16	320	640
15	160	320
14	80	160
13	40	80
12	20	40
11	10	20
10	5	10
9	2.5	5
8	1.3	2.5
7	0.64	1.3
6	0.32	0.64
5	0.16	0.32
4	0.08	0.16
3	0.04	0.08
2	0.02	0.04
1	0.01	0.02
0	0	0.01

> 4 $\mu\text{m}_{(c)}$ = 350 particles

> 6 $\mu\text{m}_{(c)}$ = 100 particles

> 14 $\mu\text{m}_{(c)}$ = 25 particles

16 / 14 / 12

ISO 4406:1999 Cleanliness Code System

Microscope counting examines the particles differently to APCs and the code is given with two scale numbers only.

These are at 5 μm and 15 μm equivalent to the 6 $\mu\text{m}_{(c)}$ and 14 $\mu\text{m}_{(c)}$ of APCs.

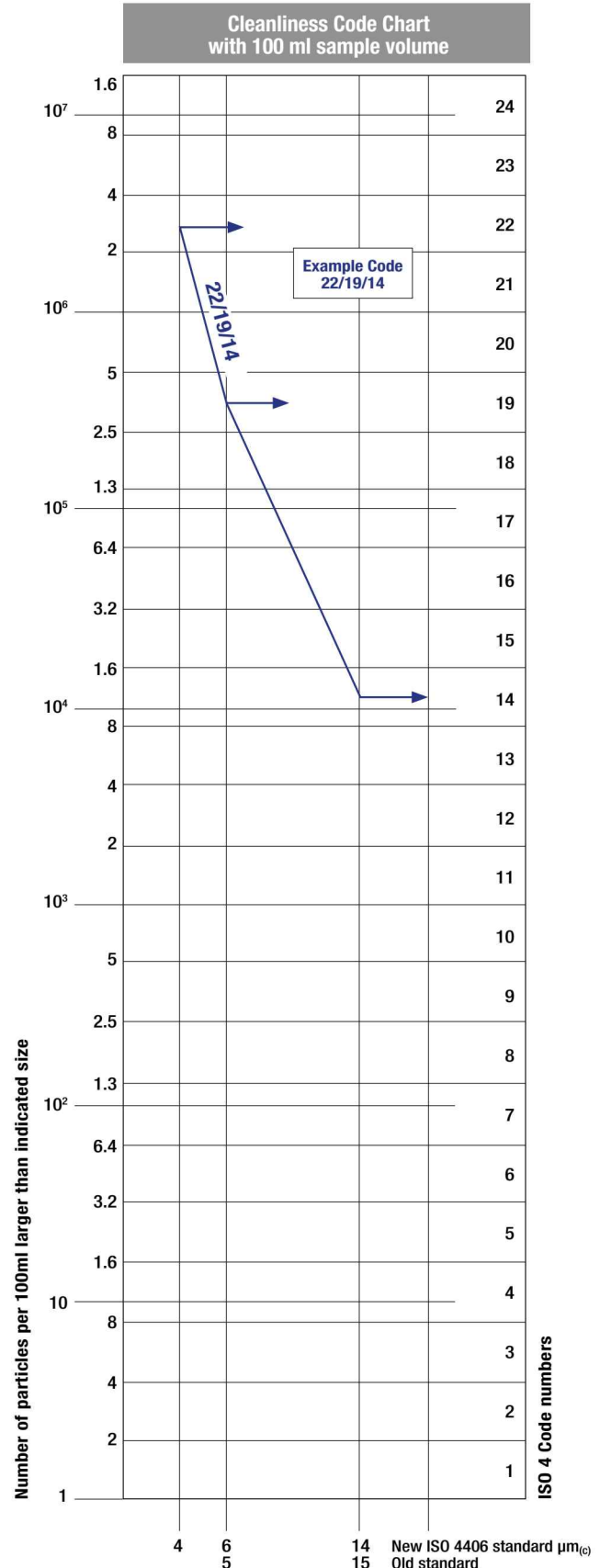

- CUMULATIVE DISTRIBUTION OF THE PARTICLES SIZE - SAE AS 4059-1 and SAE AS 4059-2

Classification example according to SAE AS 4059-1 and SAE AS 4059-2

The code, prepared for the aerospace industry, is based on the size, quantity, and particle spacing in a 100 ml fluid sample. The contamination classes are defined by numeric codes, the size of the contaminant is identified by letters (A-F).

It can be made a differential measurement (Table 1) or a cumulative measurement (Table 2)

Table 1 - Class for differential measurement

Class	Dimension of contaminant				
	6÷14 $\mu\text{m}_{(c)}$	14÷21 $\mu\text{m}_{(c)}$	21÷38 $\mu\text{m}_{(c)}$	38÷70 $\mu\text{m}_{(c)}$	>70 $\mu\text{m}_{(c)}$
00	125	22	4	1	0
0	250	44	8	2	0
1	500	89	16	3	1
2	1 000	178	32	6	1
3	2 000	356	63	11	2
4	4 000	712	126	22	4
5	8 000	1 425	253	45	8
6	16 000	2 850	506	90	16
7	32 000	5 700	1 012	180	32
8	64 000	11 400	2 025	360	64
9	128 000	22 800	4 050	720	128
10	256 000	45 600	8 100	1 440	256
11	512 000	91 200	16 200	2 880	512
12	1 024 000	182 400	32 400	5 760	1 024

6÷14 $\mu\text{m}_{(c)}$ = 15 000 particles
14÷21 $\mu\text{m}_{(c)}$ = 2 200 particles
21÷38 $\mu\text{m}_{(c)}$ = 200 particles
38÷70 $\mu\text{m}_{(c)}$ = 35 particles
> 70 $\mu\text{m}_{(c)}$ = 3 particles
Class 6

Table 2 - Class for cumulative measurement

Class	Dimension of contaminant					
	>4 $\mu\text{m}_{(c)}$ A	>6 $\mu\text{m}_{(c)}$ B	>14 $\mu\text{m}_{(c)}$ C	>21 $\mu\text{m}_{(c)}$ D	>38 $\mu\text{m}_{(c)}$ E	>70 $\mu\text{m}_{(c)}$ F
000	195	76	14	3	1	0
00	390	152	27	5	1	0
0	780	304	54	10	2	0
1	1 560	609	109	20	4	1
2	3 120	1 217	217	39	7	1
3	6 250	2 432	432	76	13	2
4	12 500	4 864	864	152	26	4
5	25 000	9 731	1 731	306	53	8
6	50 000	19 462	3 462	612	106	16
7	100 000	38 924	6 924	1 224	212	32
8	200 000	77 849	13 849	2 449	424	64
9	400 000	155 698	27 698	4 898	848	128
10	800 000	311 396	55 396	9 796	1 696	256
11	1 600 000	622 792	110 792	19 592	3 392	512
12	3 200 000	1 245 584	221 584	39 184	6 784	1 024

> 4 $\mu\text{m}_{(c)}$ = 45 000 particles
> 6 $\mu\text{m}_{(c)}$ = 15 000 particles
> 14 $\mu\text{m}_{(c)}$ = 1 500 particles
> 21 $\mu\text{m}_{(c)}$ = 250 particles
> 38 $\mu\text{m}_{(c)}$ = 15 particles
> 70 $\mu\text{m}_{(c)}$ = 3 particle
Class from 2F to 4E

- CLASSES OF CONTAMINATION ACCORDING TO NAS 1638 (January 1964)

The NAS system was originally developed in 1964 to define contamination classes for the contamination contained within aircraft components.

The application of this standard was extended to industrial hydraulic systems simply because nothing else existed at the time.

The coding system defines the maximum numbers permitted of 100ml volume at various size intervals (differential counts) rather than using cumulative counts as in ISO 4406:1999. Although there is no guidance given in the standard on how to quote the levels, most industrial users quote a single code which is the highest recorded in all sizes and this convention is used on MP Filtri APC's.

The contamination classes are defined by a number (from 00 to 12) which indicates the maximum number of particles per 100 ml, counted on a differential basis, in a given size bracket.

Size Range Classes (in microns)

Maximum Contamination Limits per 100 ml					
Class	5÷15	15÷25	25÷50	50÷100	>100
00	125	22	4	1	0
0	250	44	8	2	0
1	500	89	16	3	1
2	1 000	178	32	6	1
3	2 000	356	63	11	2
4	4 000	712	126	22	4
5	8 000	1 425	253	45	8
6	16 000	2 850	506	90	16
7	32 000	5 700	1 012	180	32
8	64 000	11 400	2 025	360	64
9	128 000	22 800	4 050	720	128
10	256 000	45 600	8 100	1 440	256
11	512 000	91 200	16 200	2 880	512
12	1 024 000	182 400	32 400	5 760	1 024

5÷15 $\mu\text{m}_{(c)}$ = 42 000 particles
15÷25 $\mu\text{m}_{(c)}$ = 2 200 particles
25÷50 $\mu\text{m}_{(c)}$ = 150 particles
50÷100 $\mu\text{m}_{(c)}$ = 18 particles
> 100 $\mu\text{m}_{(c)}$ = 3 particles
Class NAS 8

- CUMULATIVE DISTRIBUTION OF THE PARTICLES SIZE - ISO 4407

The level of contamination is defined by counting the number of particles collected by a laboratory membrane per unit of fluid volume. The measurement is done by a microscope.

The membrane must be cleaned, dried and desiccated, with fluid and conditions defined by the Standard. The fluid volume is filtered through the membrane, using a suitable suction system.

The level of contamination is identified by dividing the membrane into a predefined number of areas and by counting the contaminant particles using a suitable laboratory microscope.

MICROSCOPE CONTROL AND MEASUREMENT



COMPARISON PHOTOGRAPH'S

1 graduation = 10 μm

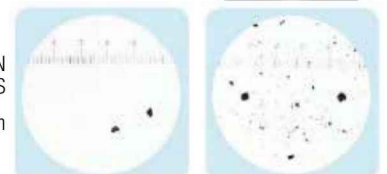

ISO 4406:1999	Class 16/14/11	Class 22/20/17
SAE AS4059E Table 1	Class 5	Class 11
NAS 1638	Class 5	Class 11
SAE AS4059E Table 2	Class 6A/5B/5C	Class 12A/11B/11C

CONTAMINATION MANAGEMENT

- CLEANLINESS CODE COMPARISON

Although ISO 4406:1999 standard is being used extensively within the hydraulics industry other standards are occasionally required and a comparison may be requested. The table below gives a very general comparison but often no direct comparison is possible due to the different classes and sizes involved.

ISO 4406:1999	SAE AS4059 Table 2	SAE AS4059 Table 1	NAS 1638
> 4 $\mu\text{m}_{(c)}$ 6 $\mu\text{m}_{(c)}$ 14 $\mu\text{m}_{(c)}$	> 4 $\mu\text{m}_{(c)}$ 6 $\mu\text{m}_{(c)}$ 14 $\mu\text{m}_{(c)}$	4-6 6-14 14-21 21-38 38-70 >70	5-15 15-25 25-50 50-100 >100
23 / 21 / 18	13A / 12B / 12C	12	12
22 / 20 / 17	12A / 11B / 11C	11	11
21 / 19 / 16	11A / 10B / 10C	10	10
20 / 18 / 15	10A / 9B / 9B	9	9
19 / 17 / 14	9A / 8B / 8C	8	8
18 / 16 / 13	8A / 7B / 7C	7	7
17 / 15 / 12	7A / 6B / 6C	6	6
16 / 14 / 11	6A / 5B / 5C	5	5
15 / 13 / 10	5A / 4B / 4C	4	4
14 / 12 / 09	4A / 3B / 3C	3	3

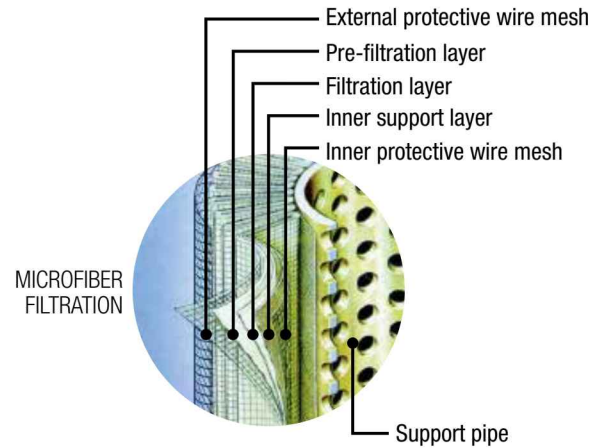

The filtration efficiency of metallic mesh filtrations is defined as the maximum particle size that can pass through the meshes of the filtering grid. The efficiency of microfibre and paper filtration ($\beta_{x(c)}$) is defined through a lab test called Multipass Test. The efficiency value ($\beta_{x(c)}$) is defined as the ratio between the number of particles of certain dimensions detected upstream and downstream of the filter.

$$\frac{\text{Upstream particles number} > X \mu\text{m}_{(c)}}{\text{Downstream particles number} > X \mu\text{m}_{(c)}} = \beta_{x(c)}$$

5 FILTRATION TECHNOLOGIES

Various mechanisms such as mechanical stoppage, magnetism, gravimetric deposit, or centrifugal separation can be used to reduce the level of contamination.

The mechanical stoppage method is most effective and can take place in two ways:

- SURFACE FILTRATION

It is by direct interception. The filter prevents particles larger than the pores from continuing in the plant / system. Surface filters are generally manufactured with metal canvases or meshes.

- DEPTH FILTERING

Filters are constructed by fiber interlacing. Such wraps form pathways of different shapes and sizes in which the particles remain trapped when they find smaller apertures than their diameter.

Depth filters are generally produced with papers impregnated with phenolic resins, metal fibers or inorganic fibers.

In inorganic fiber filtration, commonly called microfibre, the filtering layers are often overlapped in order to increase the ability to retain the contaminant.



Value ($\beta_{x(c)}$)	2	10	75	100	200	1000
Efficiency	50%	90%	98.7%	99%	99.5%	99.9%

Test conditions, such as type of fluid to be used (MIL-H-5606), type of contaminant to be used (ISO MTD), fluid viscosity, test temperature, are determined by ISO 16889.

In addition to the filtration efficiency value during the Multipass test, other important features, such as filtration stability (β stability) and dirt holding capacity (DHC), are also tested.

Poor filtration stability is the cause of the filtering quality worsening as the filter life rises. Low dirt holding capacity causes a reduction in the life of the filter.

WIRE MESH FILTRATION

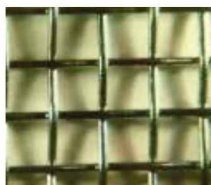

PAPER FILTRATION



Filtration ISO Standard Comparison

MP Filtri Filter media code	$\beta_{x(c)} > 1000$ ISO 16889
A03	5 $\mu\text{m}_{(c)}$
A06	7 $\mu\text{m}_{(c)}$
A10	10 $\mu\text{m}_{(c)}$
A16	15 $\mu\text{m}_{(c)}$
A25	21 $\mu\text{m}_{(c)}$

6 RECOMMENDED CONTAMINATION CLASSES

Any are the nature and the properties of fluids, they are inevitably subject to contamination. The level of contamination can be managed by using special components called filters.

Hydraulic components builders, knowing the problem of contamination, recommend the filtration level appropriate to the use of their products.

Example of recommended contamination levels

Piston pumps with fixed flow rate	•					
Piston pumps with variable flow rate			•			
Vane pumps with fixed flow rate		•				
Vane pumps with variable flow			•			
Engines	•					
Hydraulic cylinders	•					
Actuators					•	
Test benches						•
Check valve	•					
Directional valves	•					
Flow regulating valves	•					
Proportional valves				•		
Servo-valves					•	
Flat bearings			•			
Ball bearings				•		
ISO 4406 CODE	20/18/15	19/17/14	18/16/13	17/15/12	16/14/11	15/13/10
Recommended filtration $\beta_{x(c)} \geq 1.000$	$\beta_{20(c)} > 1000$	$\beta_{15(c)} > 1000$	$\beta_{10(c)} > 1000$	$\beta_{7(c)} > 1000$	$\beta_{7(c)} > 1000$	$\beta_{5(c)} > 1000$

The common classification of filters is determined by their position in the plant.

Types of filters:

Suction filters

They are positioned before the pump and are responsible for protecting the pump from dirty contaminants. It also provides additional flow guidance to the pump suction line.

Being subject to negligible working pressures are manufactured with simple and lightweight construction.

They are mainly produced with gross grade surface filtrations, mainly 60 ÷ 125 μm .

They can be equipped with a magnetic filter for retaining ferrous particles.

They are generally placed under the fluid head to take advantage of the piezometric thrust of the fluid and reduce the risk of cavitation.

There are two types of suction filters:

- IMMERSION FILTERS

Simple filter element screwed on the suction pipe

- FILTERS WITH CONTAINER

Container filters that are more bulky, but provide easier maintenance of the tank

Delivery (or Pressure) filters

They are positioned between the pump and most sensitive regulating and controlling components, such as servo valves or proportional valves, and are designed to ensure the class of contamination required by the components used in the circuit.

Being subjected to high working pressures are manufactured with more robust and articulated construction. In particular situations of corrosive environments or aggressive fluids can be made of stainless steel.

They are mainly produced with filtering depths of 3 ÷ 25 μm .

They can be manufactured with in-line connections, with plate or flange connections or directly integrated into the circuit control blocks / manifolds.

They can also be manufactured in duplex configuration to allow the contaminated section to be maintained even when the plant / system is in operation without interruption of the working cycle.

Return filters

They are positioned on the return line to the tank and perform the task of filtering the fluid from particles entering the system from the outside or generated by the wear of the components.

They are generally fixed to the reservoir (for this reason also called top tank mounted), positioned semi-immersed or completely immersed.

They are mainly produced with filtration depths of 10 ÷ 25 μm .

The positioning of the return filters must guarantee in all operating conditions that the fluid drainage takes place in immersed condition; this is to avoid creating foams in the tank that can cause malfunctions or cavitation in the pumps.

For the sizing of the return filters, account must be taken of the presence of accumulators or cylinders that can make the return flow considerably greater than the pump suction flow rate.

Being subject to contained working pressures are manufactured with simple and lightweight construction.

Normally it is possible to extract the filter element without disconnecting the filter from the rest of the system.

Combined filters

They are designed to be applied to systems with two or more circuits. They are commonly used in hydrostatic transmission machines where they have a dual filtration function of the return line and suction line of the hydrostatic transmission pump.

The filter is equipped with a valve that keeps the 0.5 bar pressure inside the filter. A portion of the fluid that returns to the tank is filtered by the return filter element, generally produced with absolute filtration, and returns to the transmission booster pump.

Only excess fluid returns to the tank through the valve.

The internal pressure of the filter and the absolute filtration help to avoid the cavitation phenomenon inside the pump.

Off-line filters

They are generally used in very large systems / plants, placed in a closed circuit independent from the main circuit. They remain in operation regardless of the operation of the main circuit and are crossed by a constant flow rate.

They can also be manufactured in duplex configuration to allow the contaminated section to be maintained even when the unit is in operation without interruption of the work cycle.

Venting filters

During the operation of the plants, the fluid level present in the reservoir changes continuously.

The result of this continuous fluctuation is an exchange of air with the outside environment.

The venting filter function, positioned on the tank, is to filter the air that enters the tank to compensate for fluid level variations.

7 FILTER CHOICE PARAMETERS

The choice of the filter system for an hydraulic system is influenced by several factors.

It is necessary to consider the characteristics of the various components present in the plant and their sensitivity to contamination.

It is also necessary to consider all the tasks that the filter will have to do within the plant:

- FLUID PROTECTION FROM CONTAMINATION
- PROTECTION OF OLEODYNAMIC COMPONENTS SENSITIVE TO CONTAMINATION
- PROTECTION OF OLEODINAMIC PLANTS FROM ENVIRONMENTAL WASTE
- PROTECTION OF OLEODINAMIC PLANTS FROM CONTAMINATION CAUSED BY COMPONENTS' FAILURES

The advantages of proper positioning and sizing of the filters are

- MORE RELIABILITY OF THE SYSTEM
- LONGER LIFE OF THE FLUID COMPONENTS
- REDUCTION OF STOP TIME
- REDUCTION OF FAILURE CASUALTIES

Each hydraulic filter is described by general features that identify the possibility of use in different applications.

- **MAXIMUM WORKING PRESSURE (P_{max})**

The maximum working pressure of the filter must be greater than or equal to the pressure of the circuit section in which it will be installed.

- **PRESSURE DROP (ΔP)**

The pressure drop depends on a number of factors, such as the working circuit temperature, the fluid viscosity, the filter element cleaning condition.

- **WORKING TEMPERATURE (T)**

The working temperature deeply affect the choice of materials. Excessively high or low temperatures may adversely affect the strength of the materials or the characteristics of the seals.

- **FILTRATION EFFICIENCY (%) / FILTRATION RATIO ($\beta_{x(c)}$)**

Filtration efficiency is the most important parameter to consider when selecting a filter.

When choosing the filtration performances, the needs of the most sensitive components in the system must be considered.

- **FLUID TYPE**

The type of fluid influences the choice of filters in terms of compatibility and viscosity. It is always mandatory to check the filterability.

- **PLACEMENT IN THE PLANT**

The position of the filter in the system conditions the efficiency of all filter performances.

8 APPLICABLE STANDARDS FOR FILTER DEVELOPMENT

In order to obtain unique criteria for development and verification of the filters performance, specific regulations for the filters and filter elements testing have been issued by ISO. These norms describe the target, the methodology, the conditions and the presentation methods for the test results.

ISO 2941

Hydraulic fluid power -- Filter elements -- Verification of collapse/burst pressure rating

This Standard describes the method for testing the collapse / burst resistance of the filter elements.

The test is performed by crossing the contaminated fluid filter element at a predefined flow rate. The progressive clogging of the filter element, determined by contamination, causes an increase in differential pressure.

ISO 2942

Hydraulic fluid power -- Filter elements -- Verification of fabrication integrity and determination of the first bubble point

This Standard describes the method to verify the integrity of the assembled filter elements.

It can be used to verify the quality of the production process or the quality of the materials by verifying the pressure value of the first bubble point.

ISO 2943

Hydraulic fluid power -- Filter elements -- Verification of material compatibility with fluids

This Standard describes the method to verify the compatibility of materials with certain hydraulic fluids.

The test is carried out by keeping the element (the material sample) immersed in the fluid under high or low temperature conditions for a given period of time and verifying the retention of the characteristics.

ISO 3723

Hydraulic fluid power -- Filter elements -- Method for end load test

This Standard describes the method for verifying the axial load resistance of the filter elements.

After performing the procedure described in ISO 2943, the designed axial load is applied to the filter element. To verify the test results, then the test described in ISO 2941 is performed.

ISO 3968

Hydraulic fluid power -- Filters -- Evaluation of differential pressure versus flow characteristics

This Standard describes the method for checking the pressure drop across the filter.

The test is carried out by crossing the filter from a given fluid and by detecting upstream and downstream pressures.

Some of the parameters defined by the Standard are the fluid, the test temperature, the size of the tubes, the position of the pressure detection points.

ISO 16889

Hydraulic fluid power -- Filters -- Multi-pass method for evaluating filtration performance of a filter element

This Standard describes the method to check the filtration characteristics of the filter elements.

The test is performed by constant introduction of contaminant (ISO MTD). The characteristics observed during the test are the filtration efficiency and the dirty holding capacity related to the differential pressure.

ISO 23181

Hydraulic fluid power -- Filter elements -- Determination of resistance to flow fatigue using high viscosity fluid

This Standard describes the method for testing the fatigue resistance of the filter elements.

The test is carried out by subjecting the filter to continuous flow variations, thus differential pressure, using a high viscosity fluid.

ISO 11170

Hydraulic fluid power -- Sequence of tests for verifying performance characteristics of filter elements

The Standard describes the method for testing the performance of filter elements. The protocol described by the regulations provides the sequence of all the tests described above in order to verify all the working characteristics (mechanical, hydraulic and filtration).

ISO 10771-1

Hydraulic fluid power -- Fatigue pressure testing of metal pressure-containing envelopes -- Test method

This Standard describes the method to check the resistance of the hydraulic components with pulsing pressure.

It can be applied to all metal components (excluding tubes) subject to cyclic pressure used in the hydraulic field.

The correct filter sizing have to be based on the variable pressure drop depending by the application. For example, for the return filter the pressure drop have to be in the range 0.4 - 0.6 bar.

The pressure drop calculation is performed by adding together the value of the housing with the value of the filter element. The pressure drop in the housing is proportional to the fluid density (kg/dm³); all the graphs in the catalogue are referred to mineral oil with density of 0.86 kg/dm³.

The filter element pressure drop is proportional to its viscosity (mm²/s), the corrective factor Y is related to an oil viscosity different than 30 mm²/s.

Sizing data for single cartridge, head at top

Δp_c = Filter housing pressure drop [bar]

Δp_e = Filter element pressure drop [bar]

Y = Multiplication factor Y (see correspondent table), depending on the filter element size, on the filter element length and on the filter media

Q = flow rate (l/min)

V1 reference viscosity = 30 mm²/s (cSt)

V2 = operating viscosity in mm²/s (cSt)

$\Delta p_e = Y : 1000 \times Q \times (V2/V1)$

$\Delta p_{Tot.} = \Delta p_c + \Delta p_e$

Calculation examples with HLP Mineral oil Variation in viscosity

Application data:

Top tank return filter

Filter with in-line connections

Pressure Pmax = 10 bar

Flow rate Q = 120 l/min

Viscosity V2 = 46 mm²/s (cSt)

Oil viscosity = 0.86 kg/dm³

Required filtration efficiency = 25 µm with absolute filtration

With bypass valve and 1 1/4" inlet connection

From the working pressure and the flow rate we understand it should be possible using the following top tank return filter series: MPT, MPH and FRI. Let's proceed with MPT series.

The size 20 doesn't achieve the required flow rate, therefore we have to consider the size 100. The final version of size 100 (101, 104, 110, 120 and 114) will be then defined in function of the mounting characteristics.

$\Delta p_c = 0.03 \text{ bar}$ (★ see graphic below, considering size 100 with the max available length to get the lowest pressure drop)

$\Delta p_e = (2.0 : 1000) \times 120 \times (46/30) = 0.37 \text{ bar}$

$\Delta p_{Tot.} = 0.03 + 0.37 = 0.4 \text{ bar}$

The selection is correct because the total pressure drop value is inside the admissible range for top tank return filters. It is of course possible trying to find a different solution, according to the mounting position or to other commercial need, repeating the previous steps while using a different series or length.

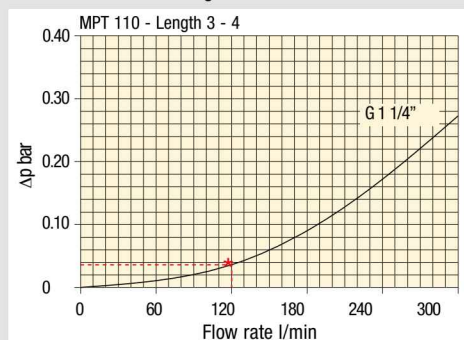

Filter housings Δp pressure drop.

The curves are plotted using mineral oil with density of 0.86 kg/dm³ in compliance with ISO 3968. Δp varies proportionally with density.

Corrective factor Y, to be used for the filter element pressure drop calculation. The values depend to the filter size and length and to the filter media.

Reference viscosity 30 mm²/s

Return filters

Filter element	Absolute filtration H Series					Nominal filtration N Series			
	Type	A03	A06	A10	A16	A25	P10	P25	M25 M60 M90
MF 020	1	74.00	50.08	20.00	16.00	9.00	6.43	5.51	4.40
	2	29.20	24.12	8.00	7.22	5.00	3.33	2.85	2.00
	3	22.00	19.00	6.56	5.33	4.33	1.68	1.44	1.30
MF 030 MFX 030	1	74.00	50.08	20.00	16.00	9.00	6.43	5.51	3.40
MF 100 MFX 100	1	28.20	24.40	8.67	8.17	6.88	4.62	3.96	1.25
	2	17.33	12.50	6.86	5.70	4.00	3.05	2.47	1.10
	3	10.25	9.00	3.65	3.33	2.50	1.63	1.32	0.96
	4	6.10	5.40	2.30	2.20	2.00	1.19	0.96	0.82
MF 180 MFX 180	1	3.67	3.05	1.64	1.56	1.24	1.18	1.06	0.26
	2	1.69	1.37	0.68	0.54	0.51	0.43	0.39	0.12
MF 190 MFX 190	2	1.69	1.37	0.60	0.49	0.44	0.35	0.31	0.11
MF 400 MFX 400	1	3.20	2.75	1.39	1.33	1.06	0.96	0.87	0.22
	2	2.00	1.87	0.88	0.85	0.55	0.49	0.45	0.13
	3	1.90	1.60	0.63	0.51	0.49	0.39	0.35	0.11
MF 750 MFX 750	1	1.08	0.84	0.49	0.36	0.26	0.21	0.19	0.06
CU 025		78.00	48.00	28.00	24.00	9.33	9.33	8.51	1.25
CU 040		25.88	20.88	10.44	10.00	3.78	3.78	3.30	1.25
CU 100		15.20	14.53	5.14	4.95	2.00	2.00	0.17	1.10
CU 250		3.25	2.55	1.55	1.35	0.71	0.71	0.59	0.25
CU 630		1.96	1.68	0.85	0.72	0.42	0.42	0.36	0.09
CU 850		1.06	0.84	0.42	0.33	0.17	0.17	0.13	0.04
MR 100	1	19.00	17.00	6.90	6.30	4.60	2.94	2.52	1.60
	2	11.70	10.80	4.40	4.30	3.00	2.94	2.52	1.37
	3	7.80	6.87	3.70	3.10	2.70	2.14	1.84	1.34
	4	5.50	4.97	2.60	2.40	2.18	1.72	1.47	1.34
	5	4.20	3.84	2.36	2.15	1.90	1.60	1.37	1.34
MR 250	1	5.35	4.85	2.32	1.92	1.50	1.38	1.20	0.15
	2	4.00	3.28	1.44	1.10	1.07	0.96	0.83	0.13
	3	2.60	2.20	1.08	1.00	0.86	0.77	0.64	0.12
	4	1.84	1.56	0.68	0.56	0.44	0.37	0.23	0.11
MR 630	1	3.10	2.48	1.32	1.14	0.92	0.83	0.73	0.09
	2	2.06	1.92	0.82	0.76	0.38	0.33	0.27	0.08
	3	1.48	1.30	0.60	0.56	0.26	0.22	0.17	0.08
	4	1.30	1.20	0.48	0.40	0.25	0.21	0.16	0.08
	5	0.74	0.65	0.30	0.28	0.13	0.10	0.08	0.04
MR 850	1	0.60	0.43	0.34	0.25	0.13	0.12	0.09	0.03
	2	0.37	0.26	0.23	0.21	0.11	0.08	0.07	0.03
	3	0.27	0.18	0.17	0.17	0.05	0.04	0.04	0.02
	4	0.23	0.16	0.13	0.12	0.04	0.03	0.03	0.02

Corrective factor Y, to be used for the filter element pressure drop calculation.
The values depend to the filter size and lenght and to the filter media.

Reference viscosity 30 mm²/s

Suction filters

Filter element	Nominal filtration N Series	
	P10	P25
SF 250	65	21

Return / Suction filters

Filter element	Absolute filtration			
	A10	A16	A25	
RSX 116	1	5.12	4.33	3.85
	2	2.22	1.87	1.22
RSX 165	1	2.06	1.75	1.46
	2	1.24	1.05	0.96
	3	0.94	0.86	0.61

Low & Medium pressure filters

Filter element	Type	Absolute filtration N-W Series					Nominal filtration N Series		
		A03	A06	A10	A16	A25	P10	P25	M25
CU 110	1	16.25	15.16	8.75	8.14	5.87	2.86	2.65	0.14
	2	12.62	10.44	6.11	6.02	4.15	1.60	1.49	0.12
	3	8.57	7.95	5.07	4.07	2.40	1.24	1.15	0.11
	4	5.76	4.05	2.80	2.36	1.14	0.91	0.85	0.05
CU 210	1	5.30	4.80	2.00	1.66	1.32	0.56	0.43	0.12
	2	3.44	2.95	1.24	1.09	0.70	0.42	0.35	0.09
	3	2.40	1.70	0.94	0.84	0.54	0.33	0.23	0.05
DN	016	7.95	7.20	3.00	2.49	1.98	0.84	0.65	0.18
	025	5.00	4.53	1.89	1.57	1.25	0.53	0.41	0.11
	040	3.13	2.66	1.12	0.98	0.63	0.38	0.32	0.08
CU 400	2	3.13	2.55	1.46	1.22	0.78	0.75	0.64	0.19
	3	2.15	1.70	0.94	0.78	0.50	0.40	0.34	0.10
	4	1.60	1.28	0.71	0.61	0.40	0.34	0.27	0.08
	5	1.00	0.83	0.47	0.34	0.20	0.24	0.19	0.06
	6	0.82	0.58	0.30	0.27	0.17	0.22	0.18	0.05
	900	1	0.86	0.63	0.32	0.30	0.21	-	-
CU 950	2	1.03	0.80	0.59	0.40	0.26	-	-	0.05
	3	0.44	0.40	0.27	0.18	0.15	-	-	0.02
MR 630	7	0.88	0.78	0.36	0.34	0.16	0.12	0.96	0.47

FILTER SIZING Corrective factor

Corrective factor Y, to be used for the filter element pressure drop calculation.
The values depend to the filter size and lenght and to the filter media.

Reference viscosity 30 mm²/s

High pressure filters

Filter element	Absolute filtration N - R Series					Nominal filtration N Series	
	Type	A03	A06	A10	A16		A25
HP 011	1	332.71	250.07	184.32	152.36	128.36	-
	2	220.28	165.56	74.08	59.13	37.05	-
	3	123.24	92.68	41.48	33.08	20.72	-
	4	77.76	58.52	28.37	22.67	16.17	-
HP 039	1	70.66	53.20	25.77	20.57	14.67	4.90
	2	36.57	32.28	18.00	13.38	8.00	2.90
	3	26.57	23.27	12.46	8.80	5.58	2.20
HP 050	1	31.75	30.30	13.16	12.3	7.29	1.60
	2	24.25	21.26	11.70	9.09	4.90	1.40
	3	17.37	16.25	8.90	7.18	3.63	1.25
	4	12.12	10.75	6.10	5.75	3.08	1.07
	5	7.00	6.56	3.60	3.10	2.25	0.80
HP 065	1	58.50	43.46	23.16	19.66	10.71	1.28
	2	42.60	25.64	16.22	13.88	7.32	1.11
	3	20.50	15.88	8.18	6.81	3.91	0.58
HP 135	1	20.33	18.80	9.71	8.66	4.78	2.78
	2	11.14	10.16	6.60	6.38	2.22	1.11
	3	6.48	6.33	3.38	3.16	2.14	1.01
HP 320	1	10.88	9.73	5.02	3.73	2.54	1.04
	2	4.40	3.83	1.75	1.48	0.88	0.71
	3	2.75	2.11	1.05	0.87	0.77	0.61
	4	2.12	1.77	0.98	0.78	0.55	0.47
HP 500	1	4.44	3.67	2.30	2.10	1.65	0.15
	2	3.37	2.77	1.78	1.68	1.24	0.10
	3	2.22	1.98	1.11	1.09	0.75	0.08
	4	1.81	1.33	0.93	0.86	0.68	0.05
	5	1.33	1.15	0.77	0.68	0.48	0.04

Filter element	Absolute filtration N Series					Nominal filtration N Series	
	Type	A03	A06	A10	A16		A25
HF 320	1	3.65	2.95	2.80	1.80	0.90	0.38
	2	2.03	1.73	1.61	1.35	0.85	0.36
	3	1.84	1.42	1.32	1.22	0.80	0.35

Stainless steel high pressure filters

Filter element	Absolute filtration N Series					
	Type	A03	A06	A10	A16	A25
HP 011	1	332.71	250.07	184.32	152.36	128.36
	2	220.28	165.56	74.08	59.13	37.05
	3	123.24	92.68	41.48	33.08	20.72
	4	77.76	58.52	28.37	22.67	16.17
HP 039	2	70.66	53.20	25.77	20.57	14.67
	3	36.57	32.28	18.00	13.38	8.00
	4	26.57	23.27	12.46	0.88	5.58
	1	31.75	30.30	13.16	12.3	7.29
HP 050	2	24.25	21.26	11.70	9.09	4.90
	3	17.37	16.25	8.90	7.18	3.63
	4	12.12	10.75	6.10	5.75	3.08
	5	7.00	6.56	3.60	3.10	2.25
	1	20.33	18.80	9.71	8.66	4.78
HP 135	2	11.14	10.16	6.60	6.38	2.22
	3	6.48	6.33	3.38	3.16	2.14

Filter element	Absolute filtration H - U Series					
	Type	A03	A06	A10	A16	A25
HP 011	1	424.58	319.74	235.17	194.44	163.78
	2	281.06	211.25	94.53	75.45	47.26
	3	130.14	97.50	43.63	34.82	21.81
	4	109.39	82.25	36.79	29.37	18.40
HP 039	2	70.66	53.20	25.77	20.57	14.67
	3	36.57	32.28	18.00	13.38	8.00
	4	26.57	23.27	12.46	8.80	5.58
	1	47.33	34.25	21.50	20.50	14.71
HP 050	2	29.10	25.95	14.04	10.90	5.88
	3	20.85	19.50	10.68	8.61	4.36
	4	14.55	12.90	7.32	6.90	3.69
	5	9.86	9.34	6.40	4.80	2.50
	1	29.16	25.33	13.00	12.47	5.92
HP 135	2	14.28	11.04	7.86	7.60	4.44
	3	8.96	7.46	4.89	4.16	3.07

Step 1 Select "FILTERS"



Step 2 Choose filter group (Return Filter, Pressure Filter, etc.)

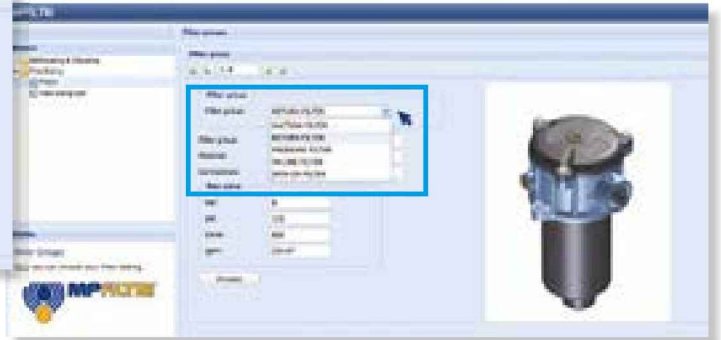

Step 3 Choose filter type (MPF, MPT, etc.) in function of the max working pressure and the max flow rate

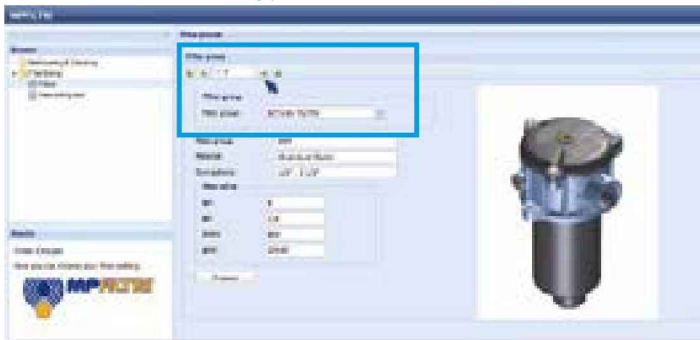

Step 4 Push "PROCEED"

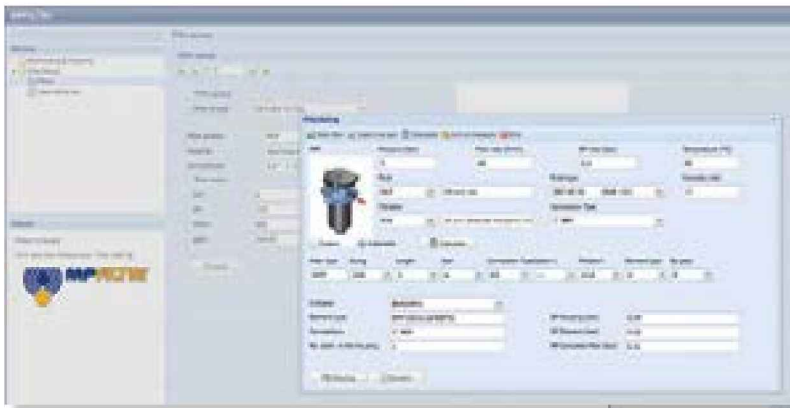
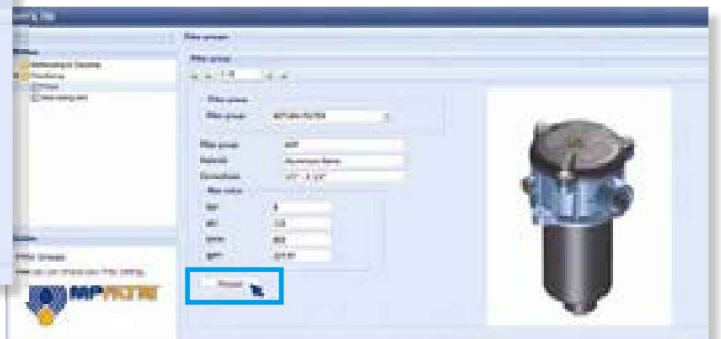

Step 5

Insert all application data to calculate the filter size following the sequence:

- working pressure
- working flow rate
- working pressure drop
- working temperature
- fluid material and fluid type
- filtration media
- connection type

Step 6

Push "CALCULATE" to have result; in case of any mistake, the system will advice which parameter is out of range to allow to modify/adjust the selection

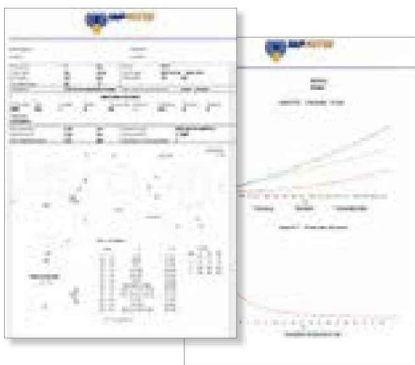
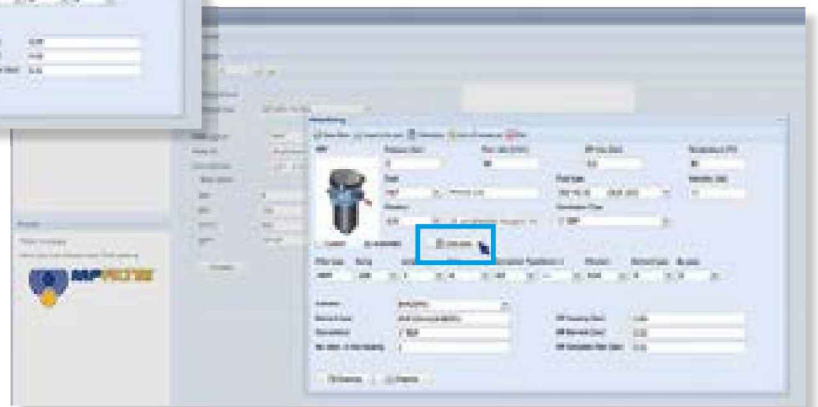

Step 7

Download PDF Datasheet "Report.aspx" pushing the button "Drawing"

Suction filters are used as safety filters to protect pumps from gross contamination which can cause them to grip.

They are available in 2 styles:

- Suction Strainer (STR, MPA, MPM)
- SF2 external filters, for mounting semi-immersed under the oil level

SF2 semi-immersed filters, which shut off oil flow while the filter element is being replaced, replace the butterfly valves usually used for servicing hydraulic pumps.



FILTER SIZING

For the proper corrective factor Y see chapter at page 21

Suction filters



STR - MPA - MPM	page 27
SF2 250 - 350	35
SF2 500	43
<hr/>	
INDICATORS	53

STR & MPA - MPM series

Flow rate up to 875 l/min



STR & MPA-MPM GENERAL INFORMATION

Technical data

Suction filters Flow rate up to 875 l/min

STR materials

- 1 - Connection: Polyamide, GF reinforced
- 2 - Core tube: Tinned Steel
- 3 - Wire mesh
- 4 - End cap: Polyamide, GF reinforced
- 5 - Bypass valve: Polyamide, GF reinforced - Steel

MPA - MPM materials

- 1 - Connection: Aluminium
- 2 - Magnetic column
- 3 - Tie rod: Galvanized Steel
- 4 - End cap: Galvanized Steel
- 5 - Core tube: Galvanized Steel
- 6 - Filter media: Wire mesh
- 7 - Bottom: Galvanized Steel
- 8 - Washer: Galvanized Steel
- 9 - Self-locking nut: Galvanized Steel - Nylon

Bypass valve

Opening pressure 30 kPa (0.3 bar)

Elements

Fluid flow through the filter element from OUT to IN.

Temperature

From -25 °C to +110 °C

Weights [kg]

STR	see page 31
MPA - MPM	see page 33

Hydraulic symbols

STR - MPA - MPM
Style S

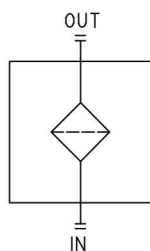

STR
Style B

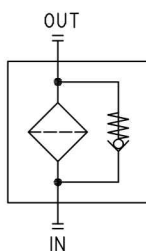

STR



Pressure drop

The curves are plotted using mineral oil with density of 0.86 kg/dm³ in compliance with ISO 3968.

Δp varies proportionally with density.

Filters pressure drop Δp in function of connection type

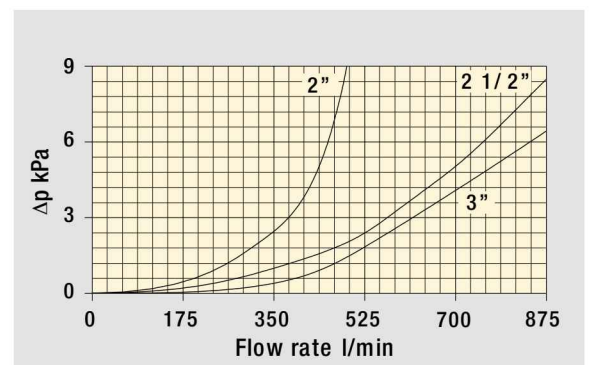
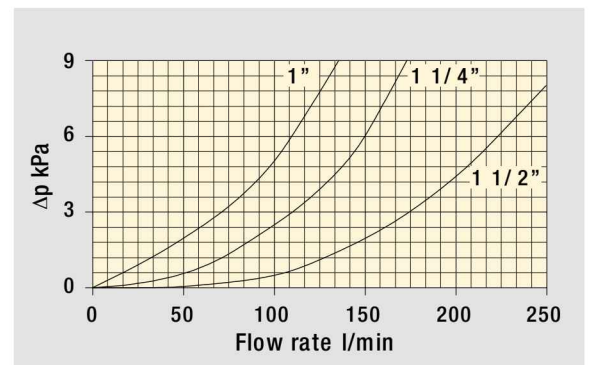
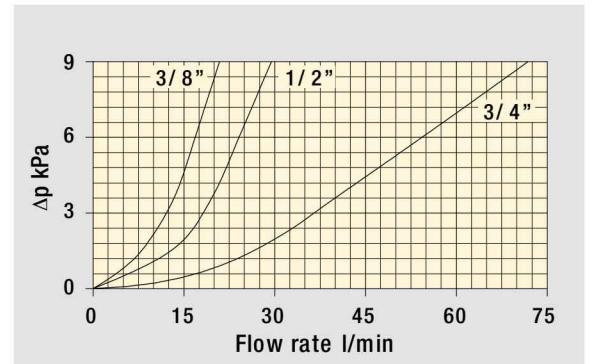

MPA

Without magnetic column



MPM

With magnetic column



COMPLETE FILTER

Element series and size

STR045
STR050
STR065
STR070
STR086
STR100
STR140
STR150

Configuration example 1: STR045 1 B G1 M60 P01

Configuration example 2: STR100 4 S G2 M250 P01

Connection nominal diameter

	STR045	STR050	STR065	STR070	STR086	STR100	STR140	STR150
1	3/8"	3/8"	1/2"	1/2"	1 1/2"	1 1/4"	1 1/2"	2"
2	1/2"	1/2"	3/4"	3/4"	2"	1 1/4"	2"	2 1/2"
3	-	-	3/4"	3/4"	1 1/2"	1 1/2"	2"	3"
4	-	-	1"	1"	2"	2"	2 1/2"	-
5	-	-	-	-	1 1/2"	1 1/2"	3"	-
6	-	-	-	1/2"	2"	-	3"	-

Valves

S	Without bypass
B	With bypass 6 bar

Connection type

G1	Thread GAS
G2	Thread NPT

Filtration rating (filter media)

M25	Wire mesh	25 µm
M60	Wire mesh	60 µm
M90	Wire mesh	90 µm
M250	Wire mesh	250 µm

OTHER INFORMATION

Conditions of packaging

Filter size	Pcs. per box
045	12
050	12
065	6
070	6
086	6
100	6
140	1
150	1

Execution

P01	MP Filtri standard
Pxx	Customized

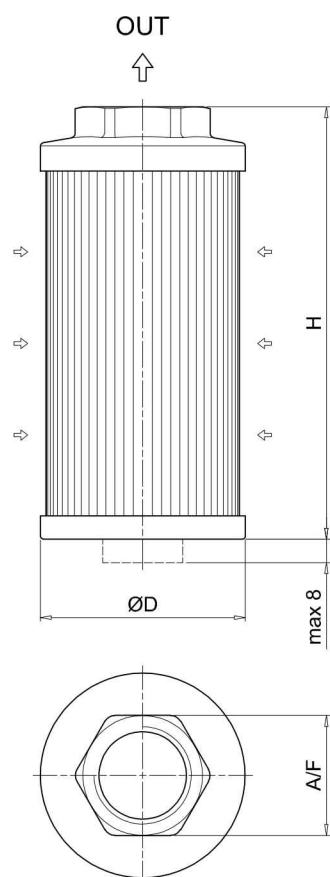

STR					
Filter size	Nominal diameter	ØD [mm]	H [mm]	A / F [mm]	Weight [kg]
045	1	46	105	30	0.15
	2	46	105	30	0.19
050	1	52	79	30	0.11
	2	52	79	30	0.11
065	1	65	110	41	0.19
	2	65	110	41	0.22
	3	65	144	41	0.24
	4	65	144	41	0.22
070	1	70	95	41	0.18
	2	70	95	41	0.17
	3	70	141	41	0.23
	4	70	141	41	0.22
	6	70	141	41	0.24
086	1	86	143	69	0.33
	2	86	143	69	0.30
	3	86	201	69	0.43
	4	86	201	69	0.40
	5	86	261	69	0.53
	6	86	261	69	0.50
100	1	99	137	69	0.47
	2	99	227	69	0.58
	3	99	227	69	0.55
	4	99	227	69	0.51
	5	99	137	69	0.43
140	1	130	160	69	0.70
	2	130	160	69	0.68
	3	130	262	69	0.94
	4	130	272	101	1.10
	5	130	272	101	1.00
	6	130	330	101	1.17
150	1	150	150	70	0.34
	2	150	212	90	0.37
	3	150	272	100	0.40

MPA-MPM

Designation & Ordering code

COMPLETE FILTER

Element series		Configuration example 1:				
MPA	Without magnetic column	MPA	030	G1	M60	P01
MPM	With magnetic column	Configuration example 2:				
		MPM	430	G2	M250	P01
Size - Connection nominal diameter						
012	3/8"					
015	1/2"					
025	1/2"					
030	3/4"					
045	3/4"					
050	1"					
075	1"					
095	1 1/4"					
120	1 1/4"					
150	1 1/2"					
180	1 1/2"					
220	2"					
280	2"					
300	2 1/2"					
380	2"					
430	3"					
Connection type						
G1	Thread GAS					
G2	Thread NPT					
Filtration rating (filter media)						
M25	Wire mesh 25 µm					
M60	Wire mesh 60 µm					
M90	Wire mesh 90 µm					
M250	Wire mesh 250 µm					
		Execution				
		P01	MP Filtri standard			
		Pxx	Customized			

OTHER INFORMATION

Conditions of packaging	
Size	Pcs. per box
012	12
015	6
025	6
030	6
045	6
050	6
075	6
095	6
120	6
150	6
180	1
220	1
280	1
300	1
380	1
430	1

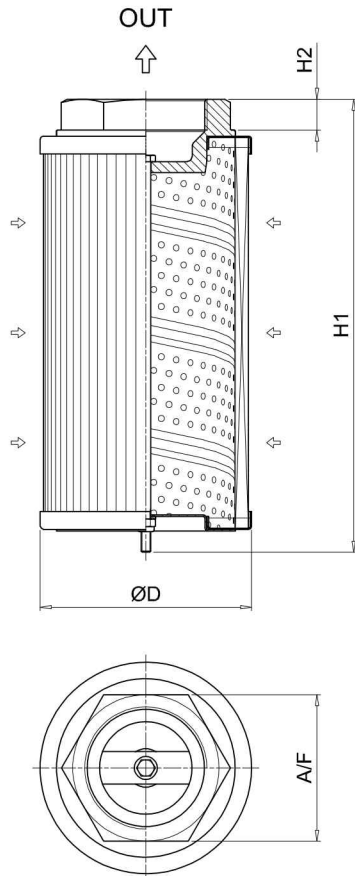

MPA					
Filter size	ØD [mm]	H1 [mm]	H2 [mm]	A/F [mm]	Weight [kg]
012	50	98	16	28	0.17
015	50	98	16	28	0.17
025	70	113	16	28	0.27
030	70	115	18	42	0.36
045	70	160	18	42	0.39
050	70	160	18	42	0.35
075	99	145	18	42	0.54
095	99	148	20	60	0.63
120	99	239	20	60	0.95
150	99	239	20	60	0.91
180	130	174	20	60	0.98
220	130	162	13	80	1.00
280	130	272	13	80	1.60
300	130	281	20	90	1.67
380	130	322	13	80	1.60
430	130	335	22	106	1.93

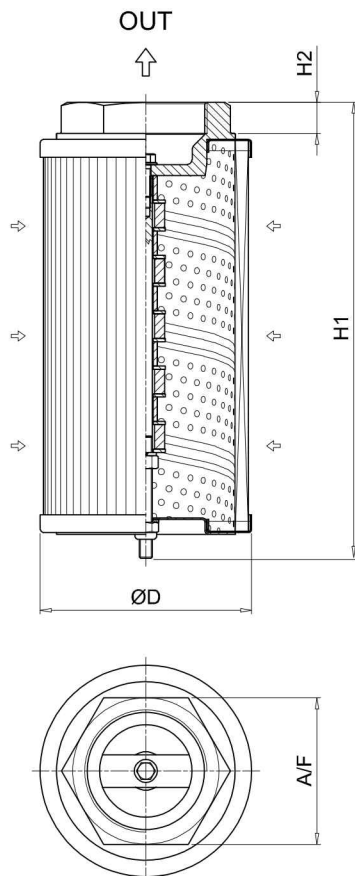

MPM					
Filter size	ØD [mm]	H1 [mm]	H2 [mm]	A/F [mm]	Weight [kg]
012	50	98	16	28	0.17
015	50	98	16	28	0.17
025	70	113	16	28	0.27
030	70	115	18	42	0.36
045	70	160	18	42	0.39
050	70	160	18	42	0.35
075	99	148	18	42	0.54
095	99	154	20	60	0.63
120	99	244	20	60	0.95
150	99	244	20	60	0.91
180	130	174	20	60	0.98
220	130	163	13	80	1.00
280	130	273	13	80	1.60
300	130	282	20	90	1.67
380	130	323	13	80	1.60
430	130	336	22	106	1.93

SF2 250-350 series

Flow rate up to 160 l/min

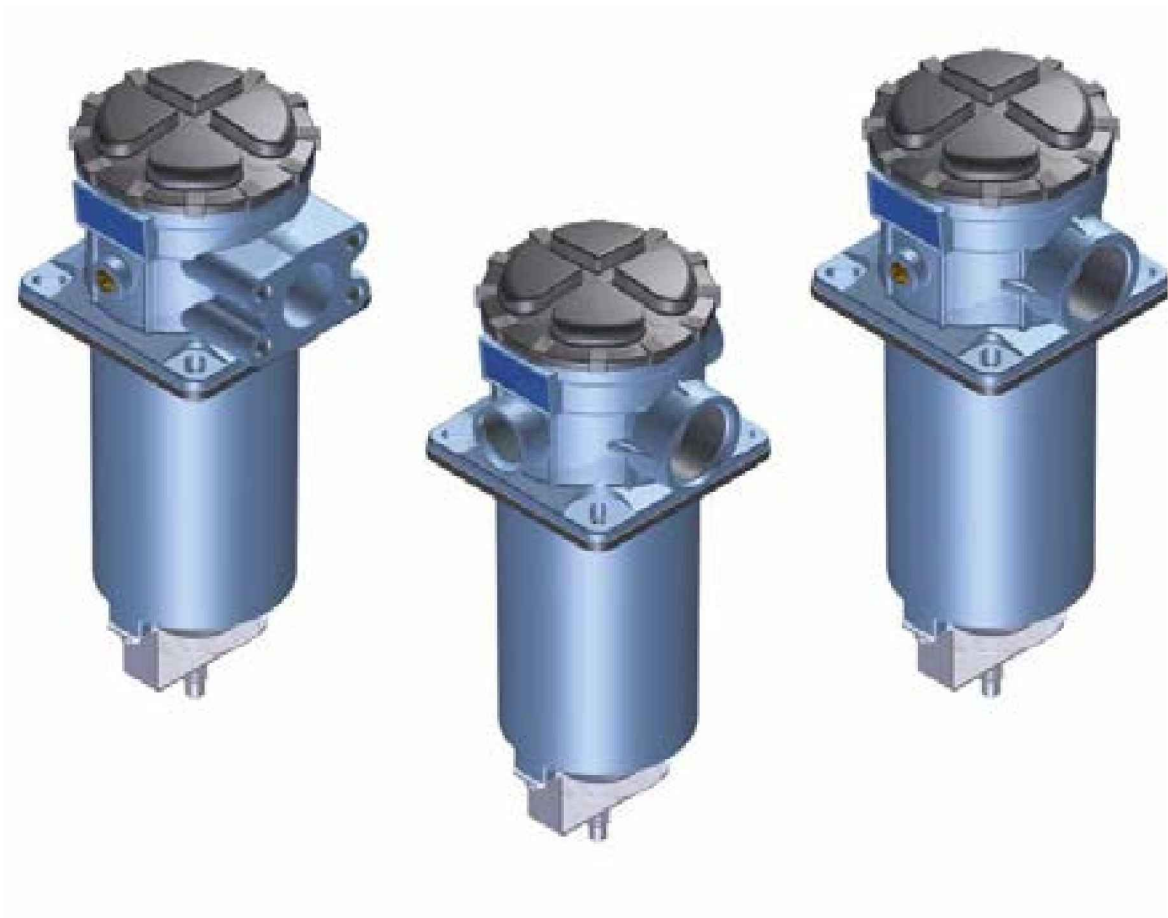

SF2 250-350 GENERAL INFORMATION

Technical data

Suction filters Flow rate up to 160 l/min

Filter housing materials

- Filter body: Aluminium
- Cover: Polyamide, GF reinforced
- Valve: Polyamide, GF reinforced - Steel
- Anti-Emptying valve: Steel

Seals

- Standard NBR series A
- Optional FPM series V

Bypass valve

Opening pressure 30 kPa (0.3 bar)

Temperature

From -25 °C to +110 °C

Elements

Fluid flow through the filter element from IN to OUT

Note

SF2 250-350 filters mounting, see the drawings on page 39 and following.

Weights [kg]

SF2 250	2.6
SF2 350	2.6

Hydraulic symbols

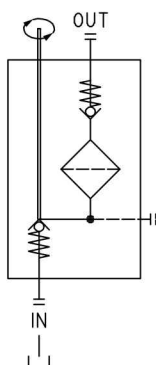

GENERAL INFORMATION SF2 250-350

The curves are plotted using mineral oil with density of 0.86 kg/dm³ in compliance with ISO 3968.
 Δp varies proportionally with density.

Filter housings Δp pressure drop

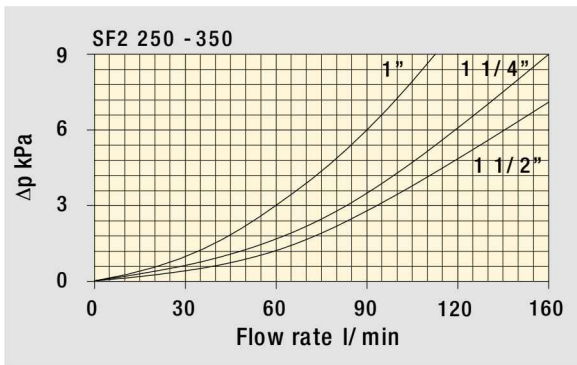

Bypass valve pressure drop

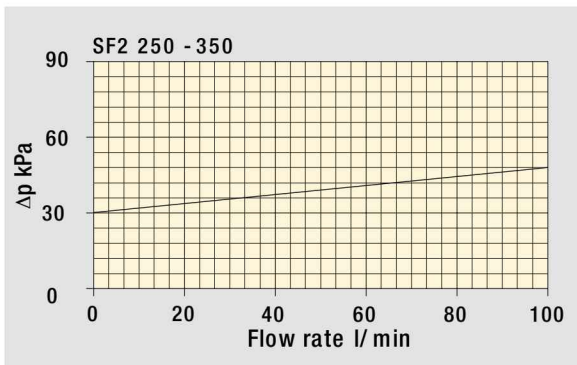

SF2 250-350

Designation & Ordering code

COMPLETE FILTER

Series and size		Configuration example 1: SF2250 W F2 R M25 P01					
SF2250		Configuration example 2: SF2350 A G1 S P25 P01					
SF2350							
Seals and treatments		Filtration rating					
		Mxx	Pxx				
A	NBR	•	•				
V	FPM	•	•				
W	NBR compatible with fluids HFA-HFB-HFC	•					
Z	FPM compatible with fluids HFA-HFB-HFC	•					
Connections		Aux (only SF2350)	SF2250	SF2350			
G1	G1 1/2"	G1"	•	•			
G2	1 1/2" NPT	-	•				
G3	SAE 24 - 1 7/8" - 12 UN	SAE 16 - 1 5/16" - 12 UN	•	•			
G4	G1 1/4"	-	•				
G5	1 1/4" NPT	-	•				
G6	SAE 20 - 1 5/8" - 12 UN	-	•				
G7	G1"	-	•				
G8	1" NPT	-	•				
G9	SAE 16 - 1 5/16" - 12 UN	-	•				
F1	1 1/2" SAE 3000 psi/M	-	•				
F2	1 1/2" SAE 3000 psi/UNC	-	•				
Bypass valve and magnetic column							
R	With bypass, with magnetic column	Q	Without bypass, with magnetic column				
S	With bypass, without magnetic column	H	Without bypass, without magnetic column				
Filtration rating (filter media)							
M25	Wire mesh 25 µm						
M60	Wire mesh 60 µm						
M90	Wire mesh 90 µm						
M250	Wire mesh 250 µm						
		Execution					
		P01 MP Filtri standard					
		Pxx Customized					

FILTER ELEMENT

Element series and size		Configuration example: SF250 M25 W P01			
SF250					
Filtration rating (filter media)					
M25	Wire mesh 25 µm				
M60	Wire mesh 60 µm				
M90	Wire mesh 90 µm				
M250	Wire mesh 250 µm				
Seals and treatments		Filtration rating			
		Mxx	Pxx		
N	NBR	•	•		
V	FPM	•	•		
W	NBR compatible with fluids HFA-HFB-HFC	•			
Z	FPM compatible with fluids HFA-HFB-HFC	•			
		Execution			
		P01 MP Filtri standard			
		Pxx Customized			

ACCESSORIES

Clogging indicators		page
VVA	Axial vacuum gauge	55
VVR	Radial vacuum gauge	55
VEA	Electrical vacuum indicator	54
VLA	Electrical / visual vacuum indicator	54

SF2 250-350

Dimensions

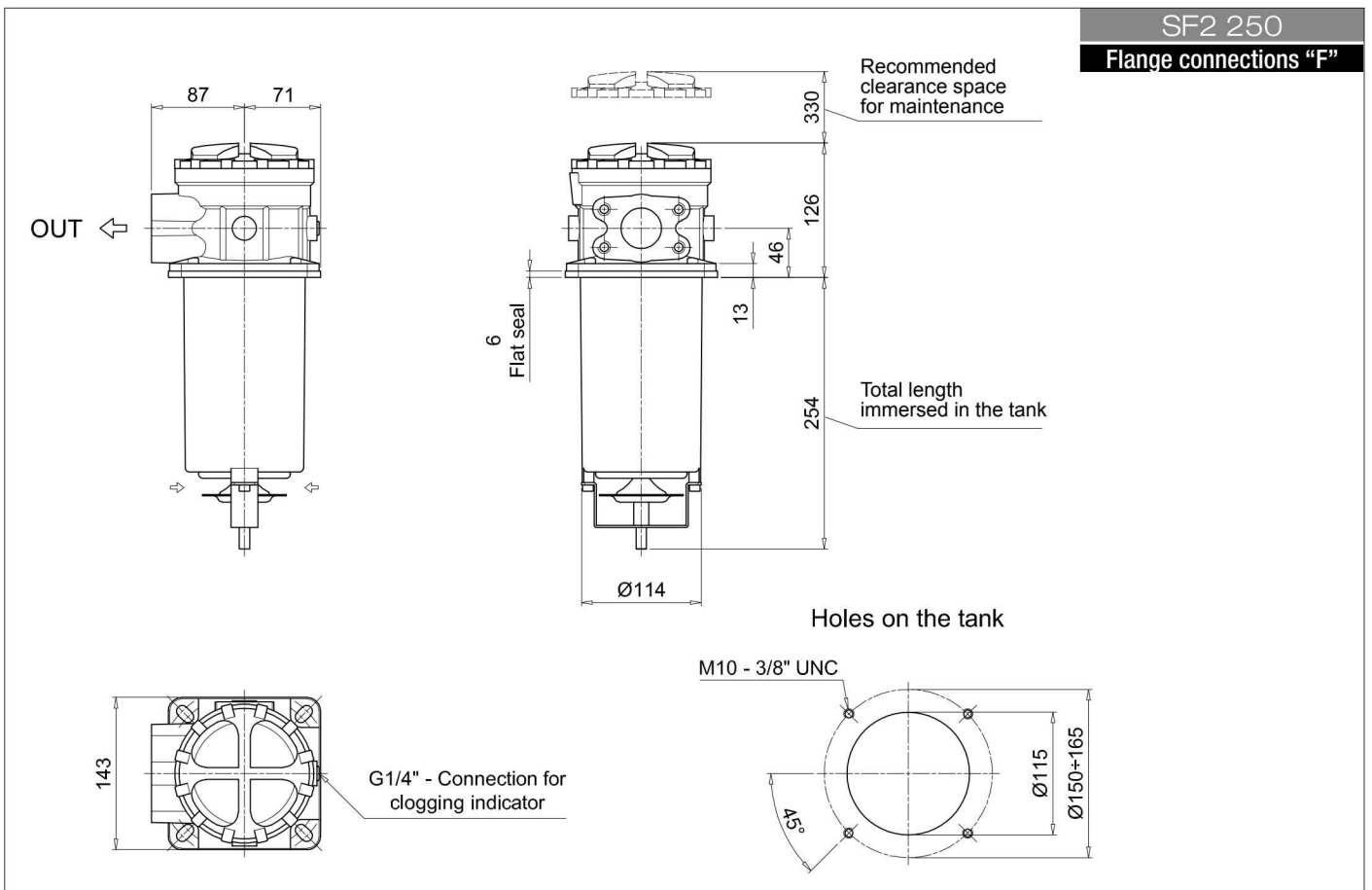
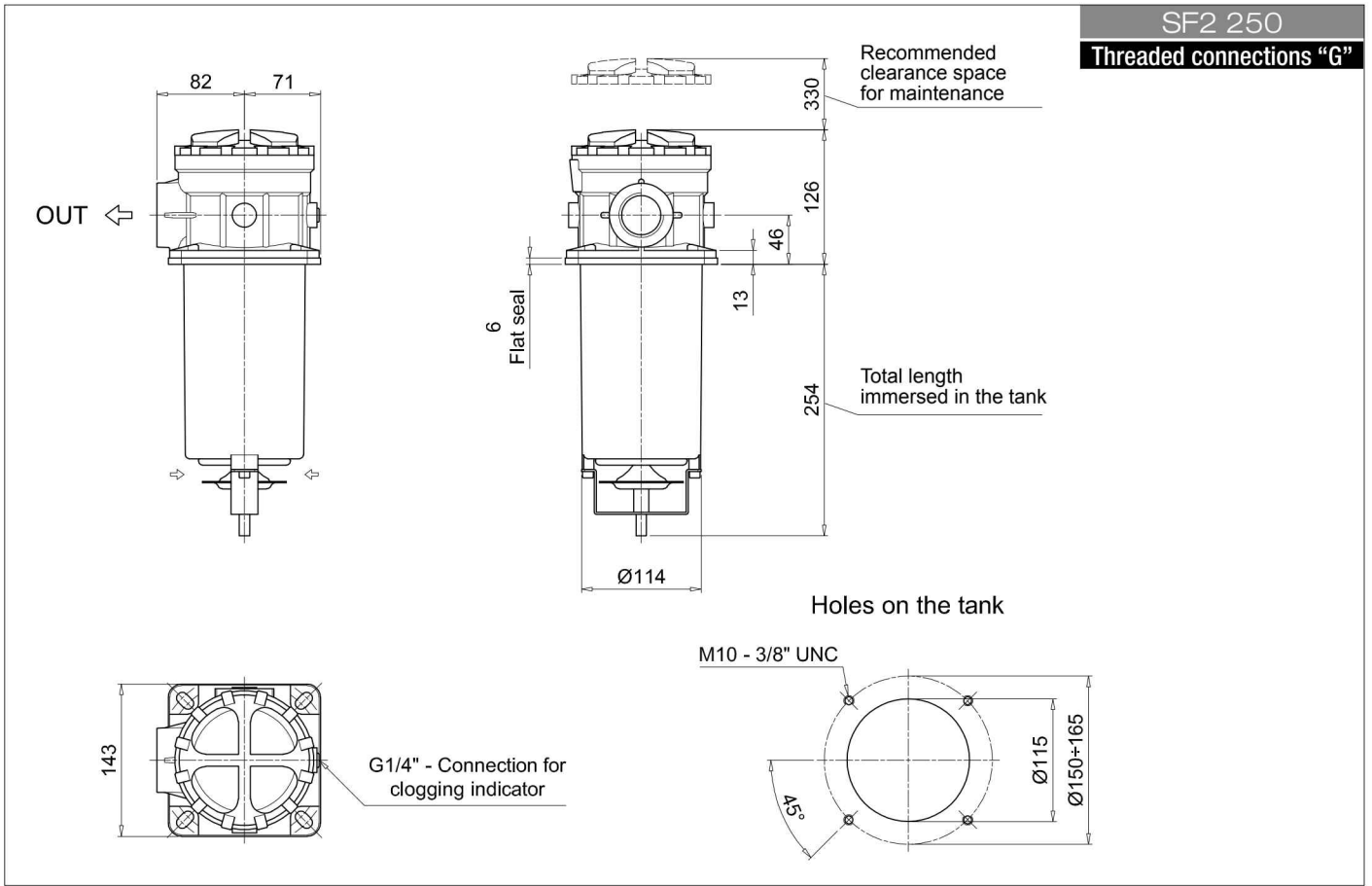

SF2 250-350

Dimensions

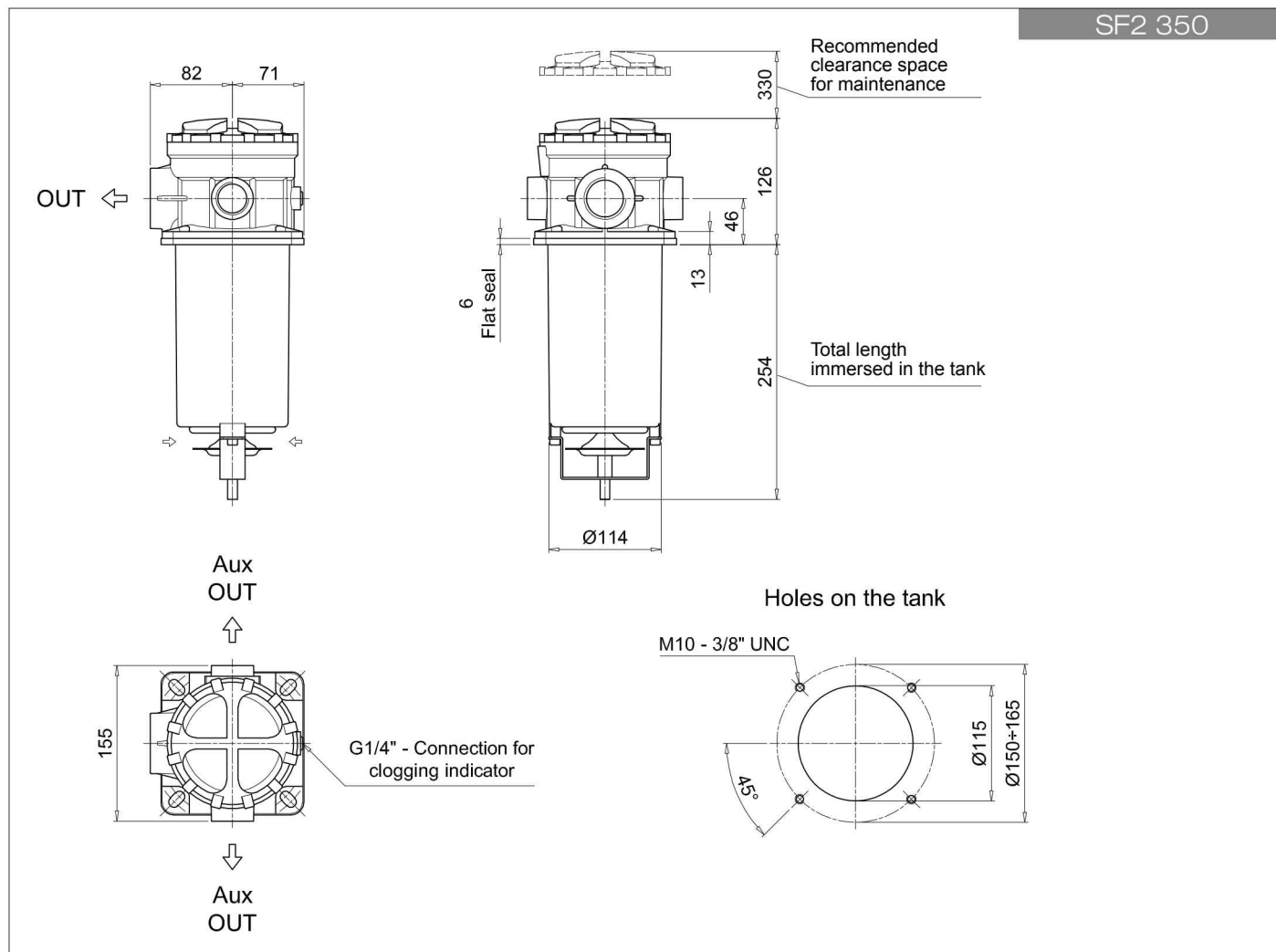

SPARE PARTS SF2 250-350

Order number for spare parts

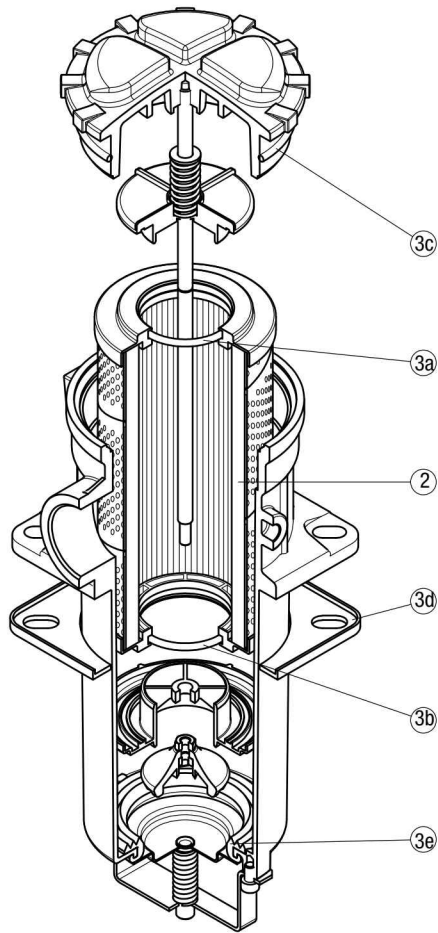

Item:	Q.ty: 1 pc.	Q.ty: 1 pc.	
Filter series	Filter element	Seal Kit code number	
		NBR	FPM
SF2 250 - 350	See order table	02050586	02050587

SF2 500 series

Flow rate up to 800 l/min



SF2 500 GENERAL INFORMATION

Technical data

Suction filters Flow rate up to 800 l/min

Filter housing materials

- Housing:
Anodized Aluminium
Steel (chemical heat treatment): only for SF2 535 - 540

- Cover:
Anodized Aluminium
Steel (chemical heat treatment): only for SF2 535 - 540

- Optional flange:
Anodized Aluminium

Seals

- Standard NBR series A
- Optional FPM series V

Temperature

From -25 °C to +110 °C

Elements

Fluid flow through the filter element from IN to OUT.

Note

SF2 500 filters mounting, see the drawings on page 47 and following.

Weights [kg]

SF2 500-501	4.0
SF2 503	4.8
SF2 504	5.8
SF2 505	6.0
SF2 510	7.2
SF2 535	17
SF2 540	19

Hydraulic symbols

SF2 500 S-M

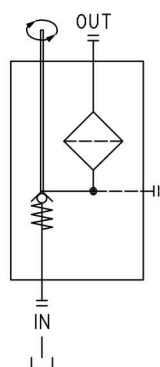

SF2 500 D-K

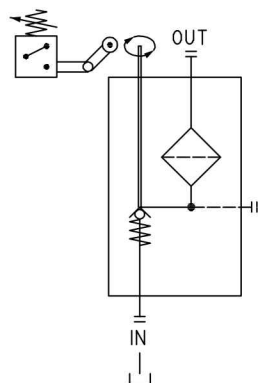

GENERAL INFORMATION SF2 500

The curves are plotted using mineral oil with density of 0.86 kg/dm³ in compliance with ISO 3968.

Δp varies proportionally with density.

Filter housings Δp pressure drop

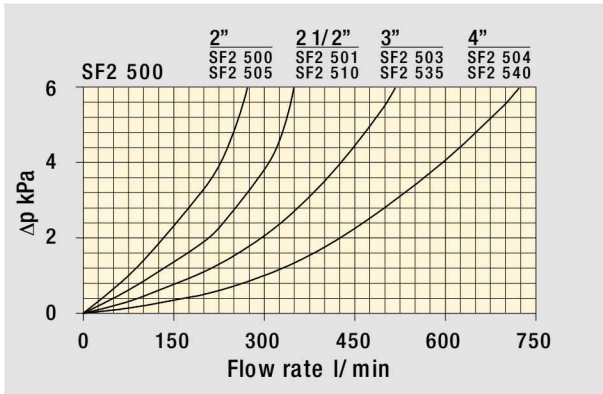

The curves are plotted using mineral oil with density of 0.86 kg/dm³ in compliance with ISO 3968.

Filter element Δp pressure drop

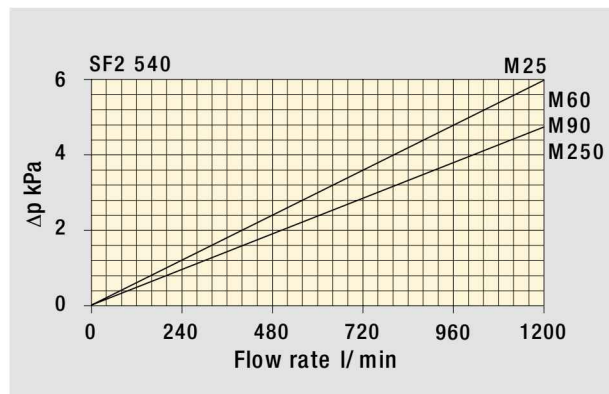
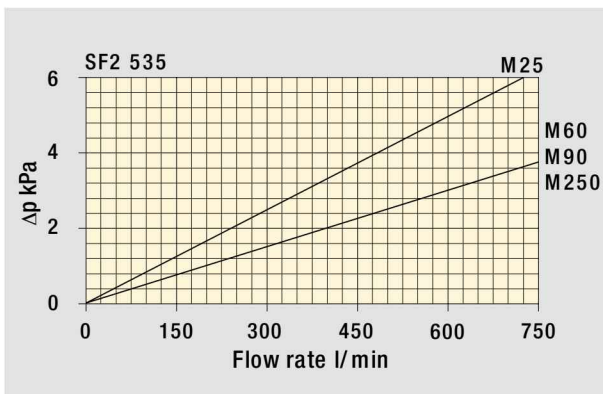
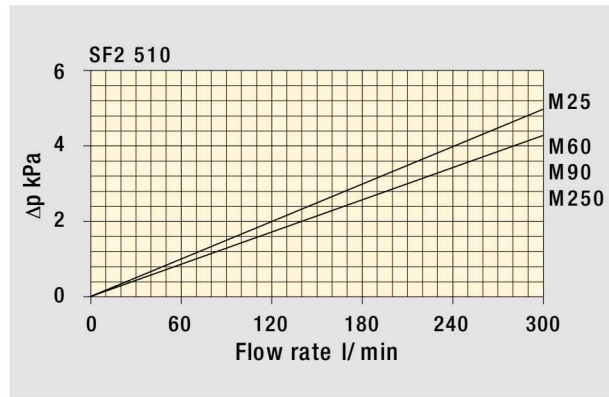
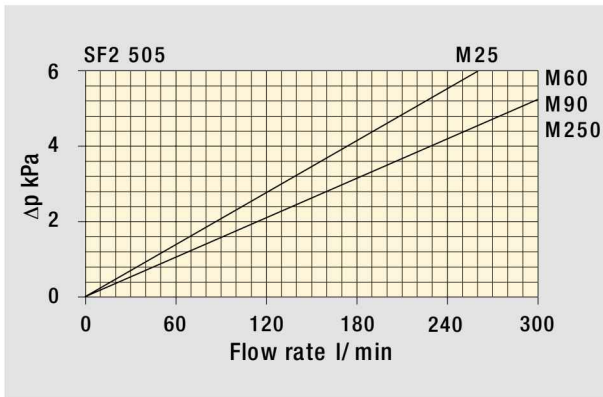
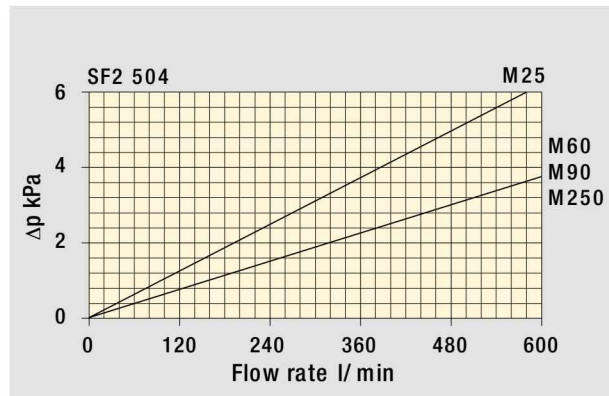
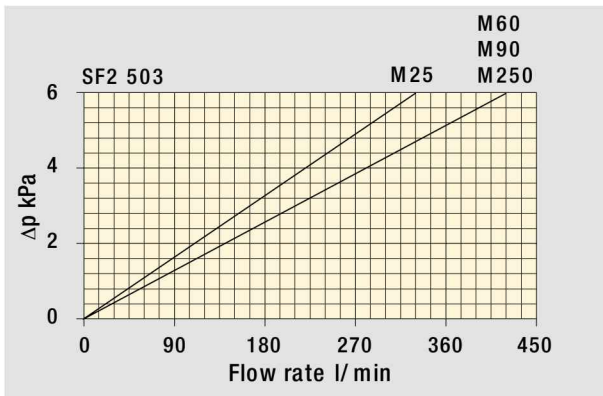

Designation & Ordering code

COMPLETE FILTER

Series and size		Configuration example 1: SF2500 W F1 D M25 P01					
SF2500		Configuration example 2: SF2535 A F2 C M60 P01					
SF2501							
SF2503							
SF2504							
SF2505							
SF2510							
SF2535							
SF2540							
Seals and treatments		Filtration rating					
		Mxx	Pxx				
A	NBR	•	•				
V	FPM	•	•				
W	NBR compatible with fluids HFA-HFB-HFC	•					
Z	FPM compatible with fluids HFA-HFB-HFC	•					
Connections							
SF2500 - SF2505		SF2501 - SF2510		SF2503 - SF2535		SF2504 - SF2540	
F1	2" SAE 3000 psi/M	2 1/2" SAE 3000 psi/M	3" SAE 3000 psi/M	4" SAE 3000 psi/M			
F2	2" SAE 3000 psi/UNC	2 1/2" SAE 3000 psi/UNC	3" SAE 3000 psi/UNC	4" SAE 3000 psi/UNC			
C1	Hose barb 2"/M	Hose barb 2 1/2"/M	Hose barb 3"/M	Hose barb 4"/M			
Microswitch and Handweel							
		SF2500 - SF2501	SF2503 - SF2504	SF2505 - SF2510	SF2535 - SF2540		
S	Without microswitch, without handwheel	•	•	•	•		
C	With microswitch, without handwheel			•	•		
D	With microswitch, with Nylon handwheel	•	•				
K	With microswitch, with steel handwheel	•	•				
M	Without microswitch, with Nylon handwheel	•	•				
Filtration rating (filter media)							
M25	Wire mesh 25 µm	M90	Wire mesh 90 µm				
M60	Wire mesh 60 µm	M250	Wire mesh 250 µm				

Execution
P01 MP Filtri standard
Pxx Customized

FILTER ELEMENT

Element series and size								Configuration example 1: SF510 M25 W P01				
								Configuration example 2: SF535 M60 P01				
	SF2500	SF2501	SF2503	SF2504	SF2505	SF2510	SF2535	SF2540				
SF503			•									
SF504				•								
SF505					•							
SF510	•	•				•						
SF535							•					
SF540								•				
Filtration rating (filter media)												
M25	Wire mesh 25 µm	M90	Wire mesh 90 µm									
M60	Wire mesh 60 µm	M250	Wire mesh 250 µm									

Seals and treatments		Filtration rating	
		Mxx	Pxx
Standard version		•	•
W	Compatible with fluids HFA-HFB-HFC	•	

Execution
P01 MP Filtri standard
Pxx Customized

ACCESSORIES

Clogging indicators		page
VVA	Axial vacuum gauge	55
VVR	Radial vacuum gauge	55
VEA	Electrical vacuum indicator	54
VLA	Electrical / visual vacuum indicator	54

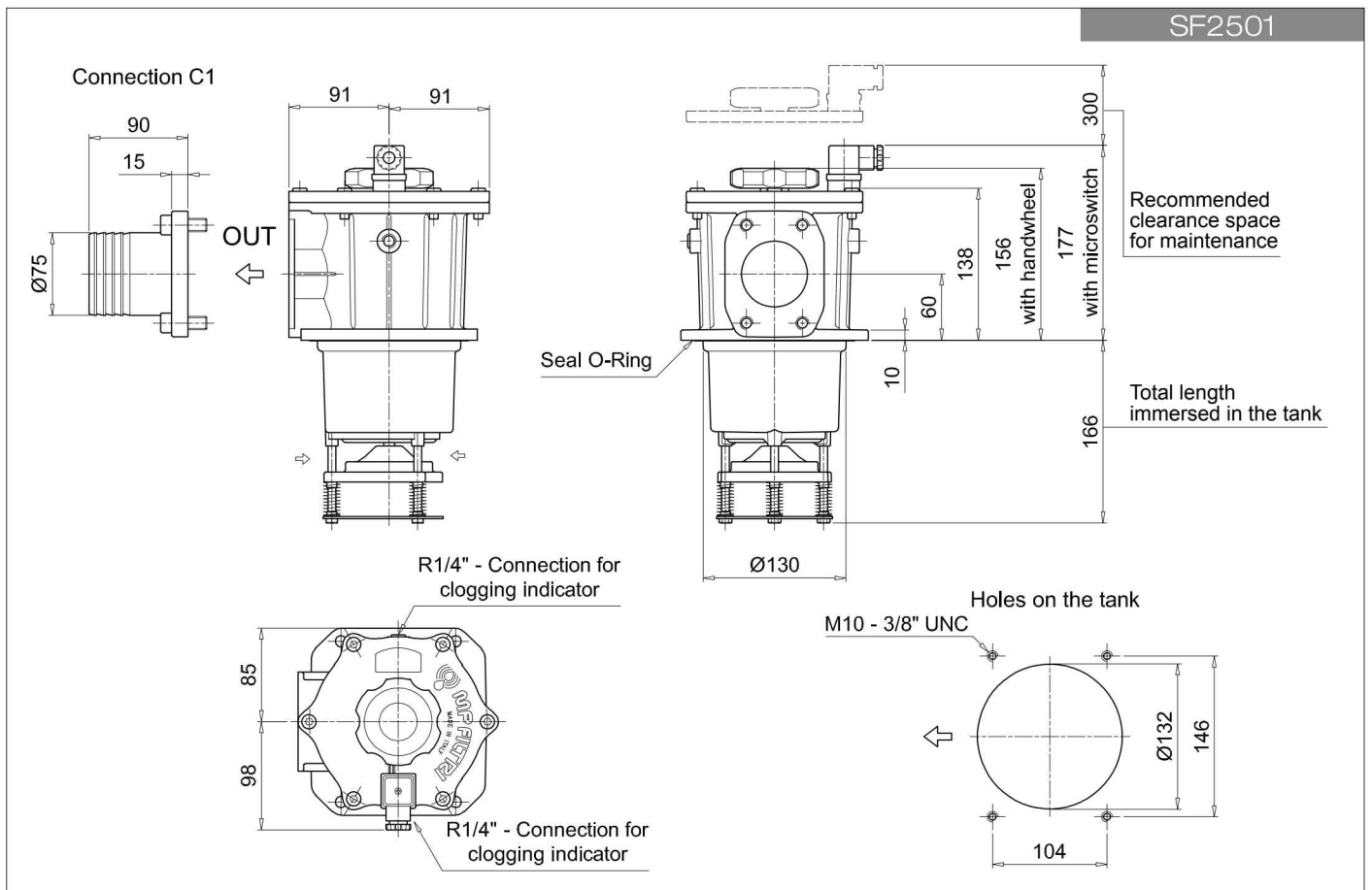
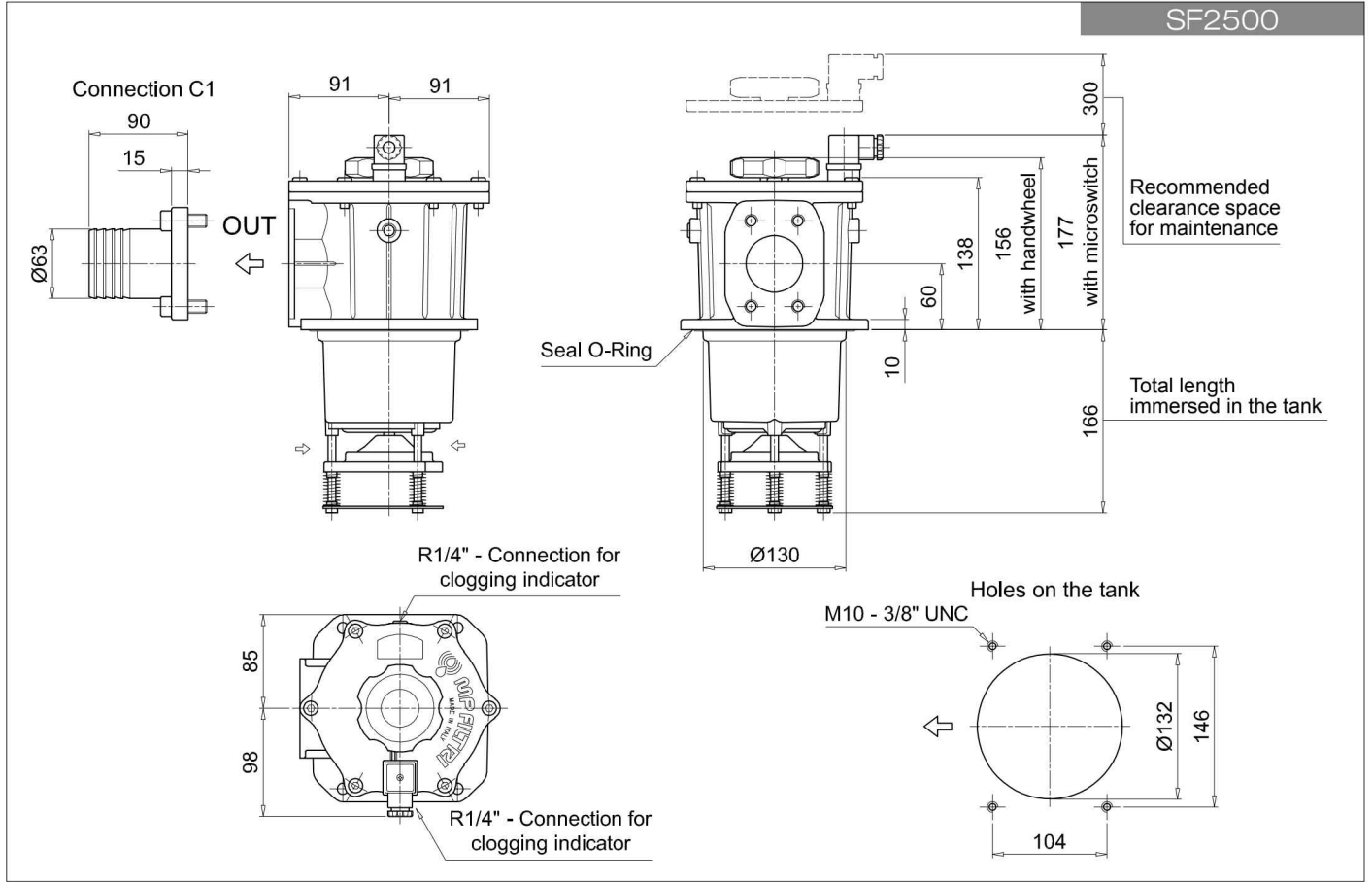

SF2 500

SF2500 - SF2501 - SF2503 - SF2504 - SF2505 - SF25010 - SF2535 - SF2540

Dimensions

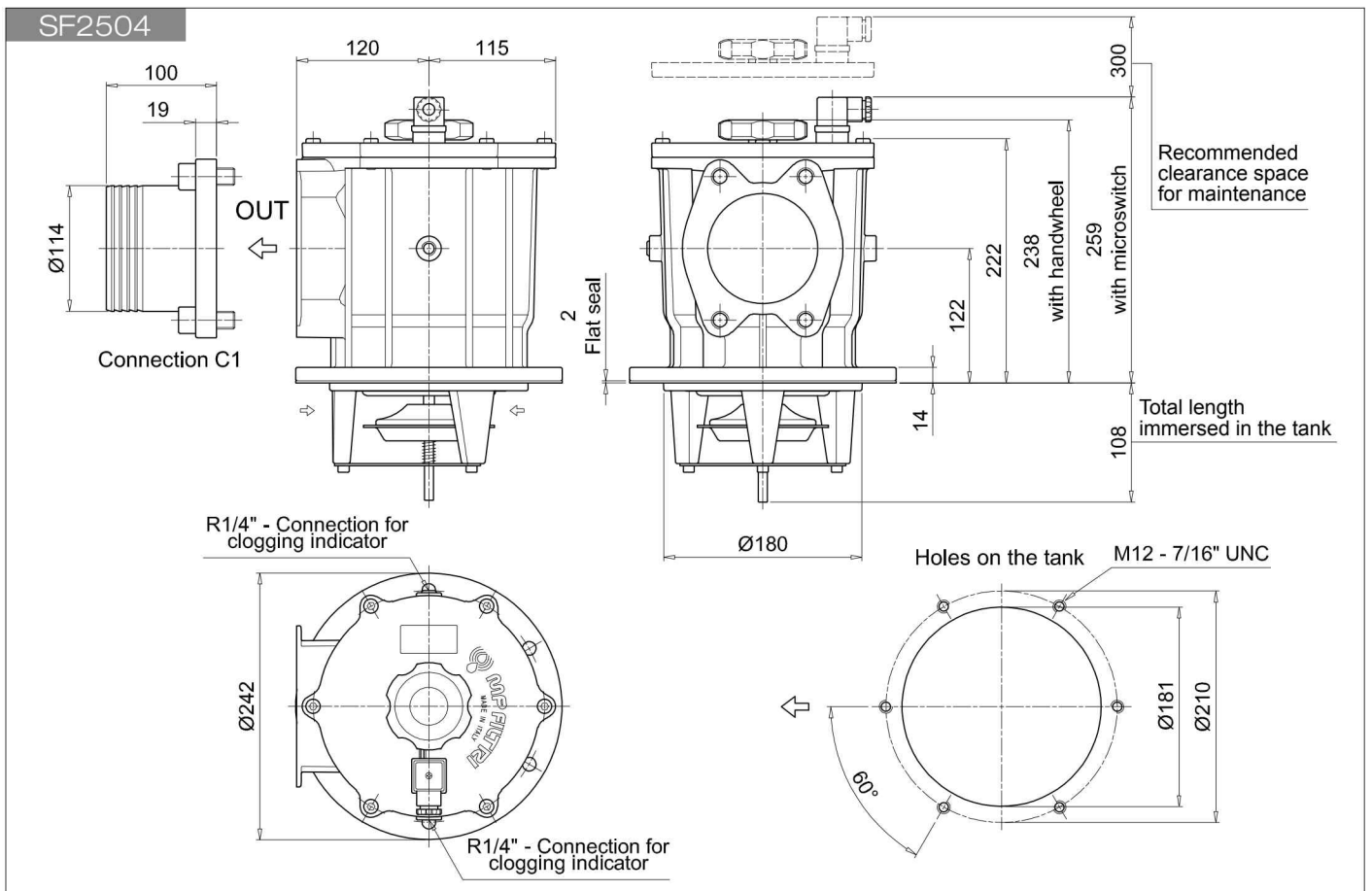
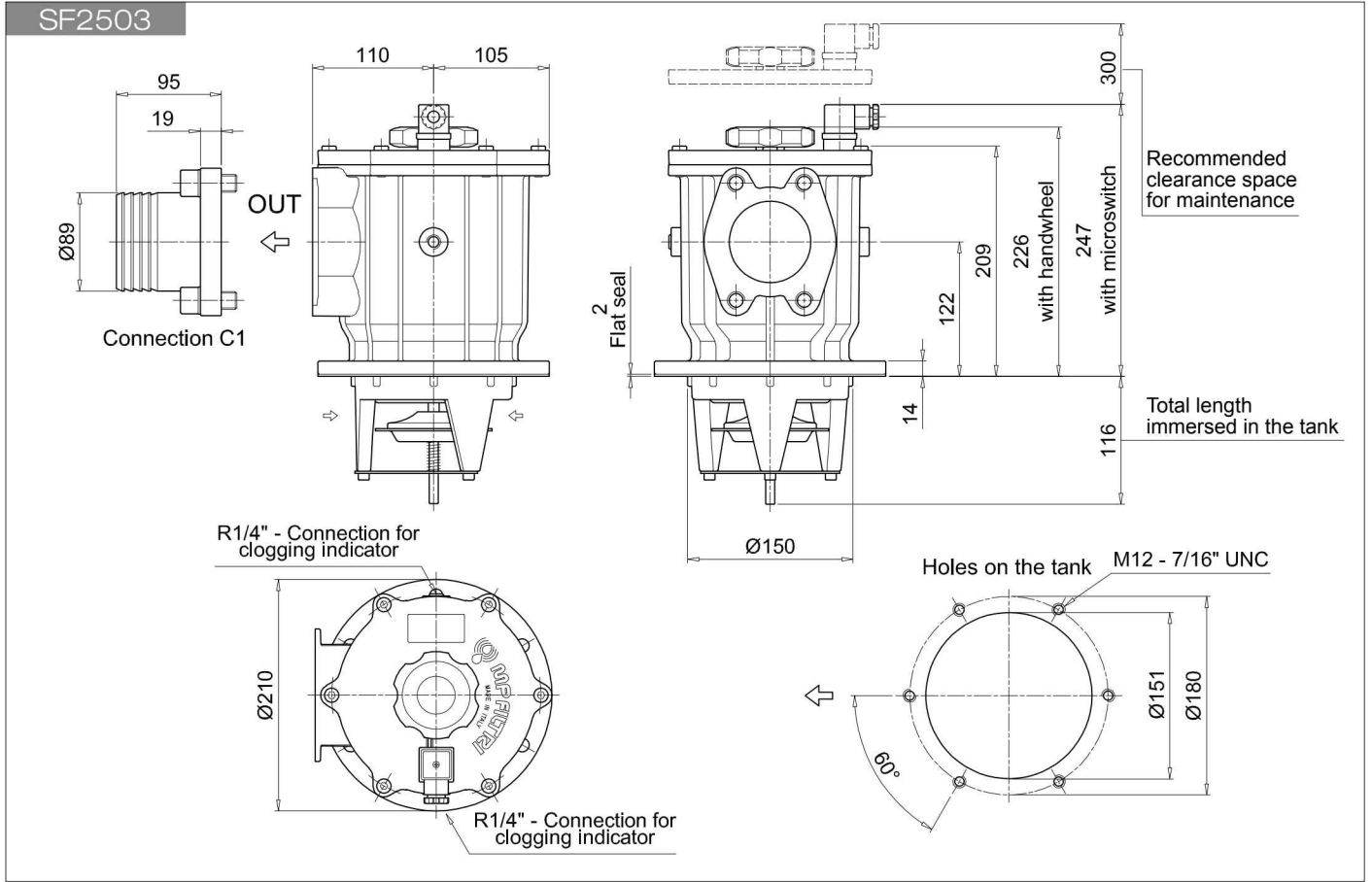

SF2505

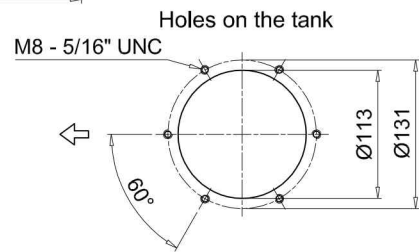
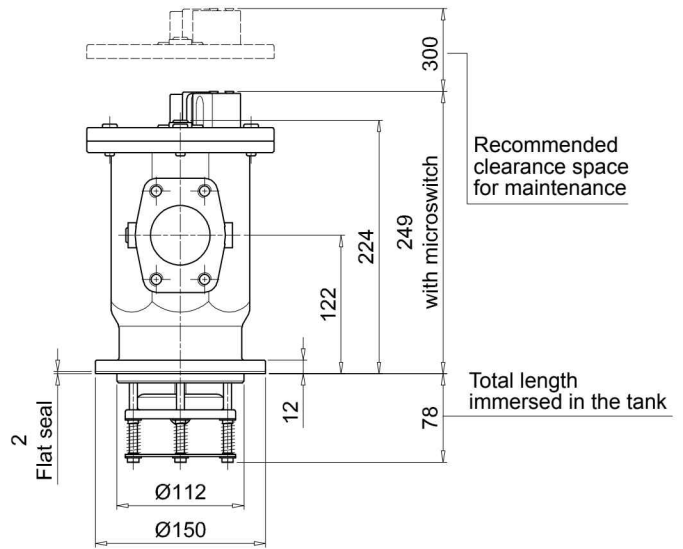
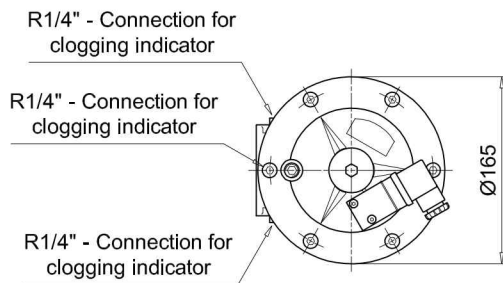
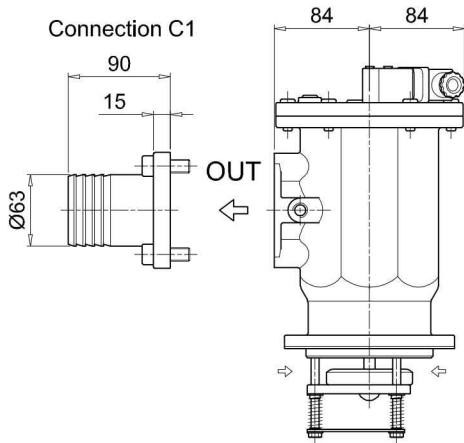

SF2510

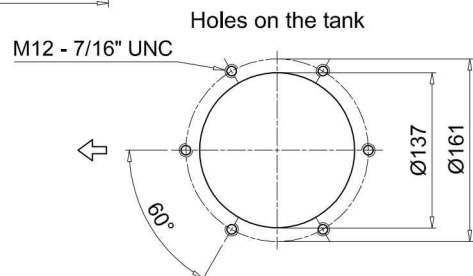
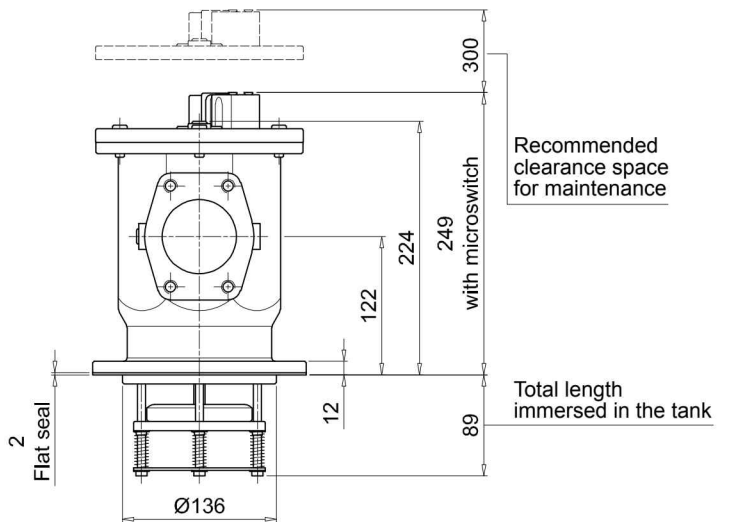
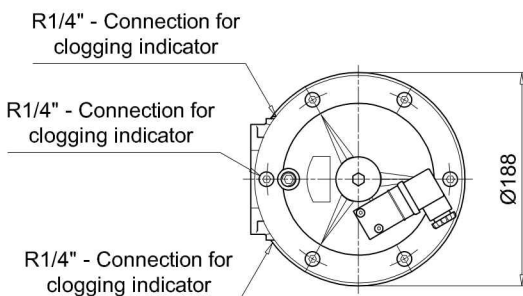
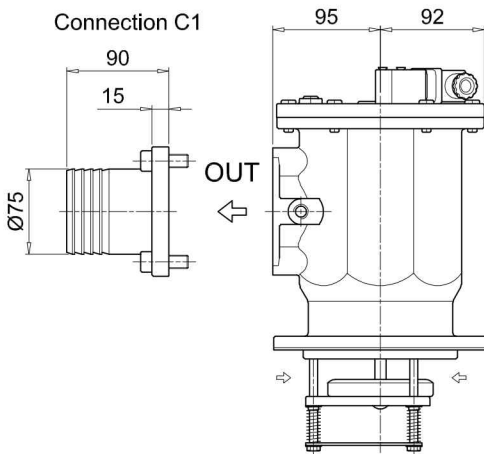

SF2 500

SF2500 - SF2501 - SF2503 - SF2504 - SF2505 - SF25010 - SF2535 - SF2540

Dimensions

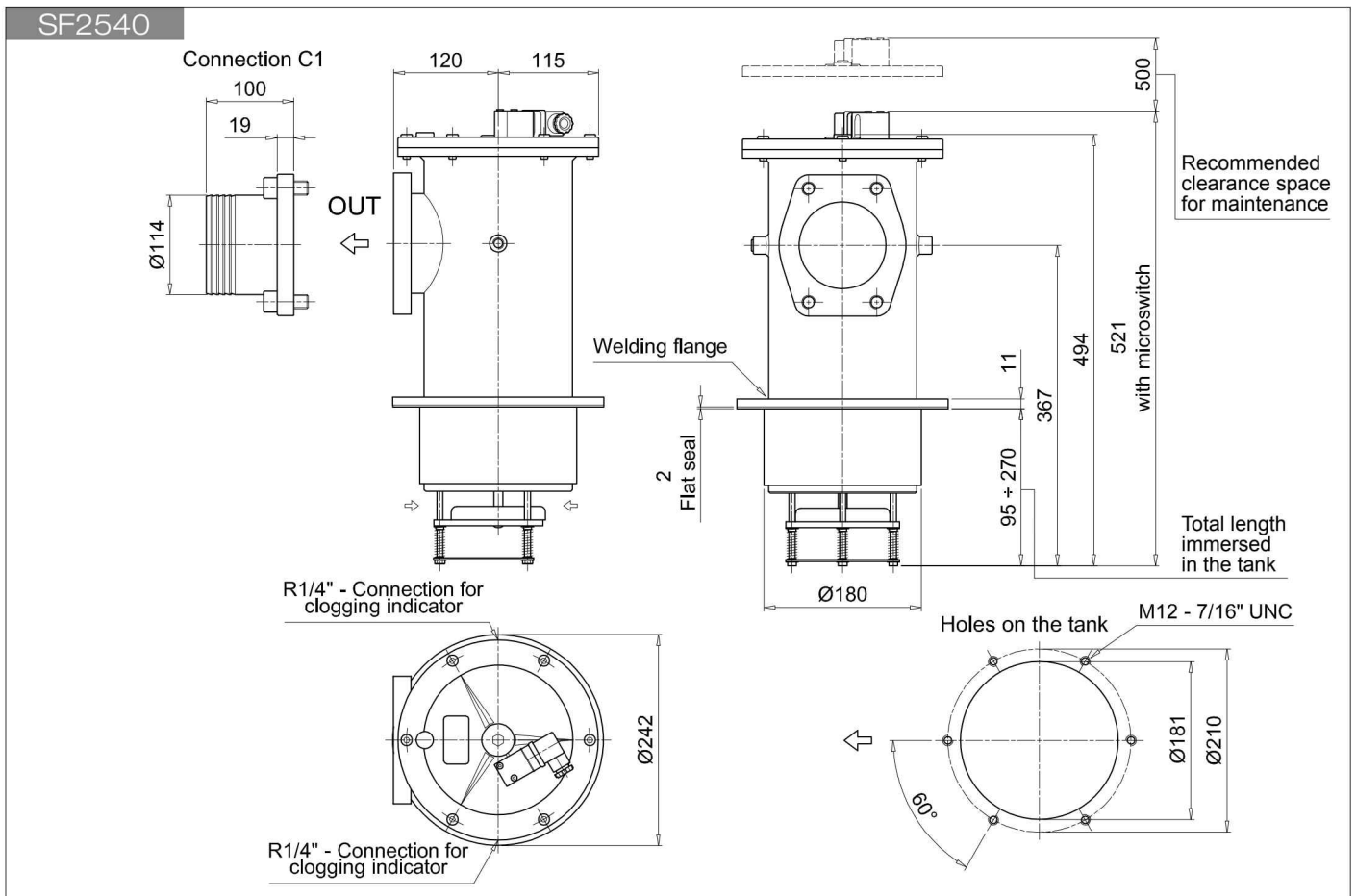
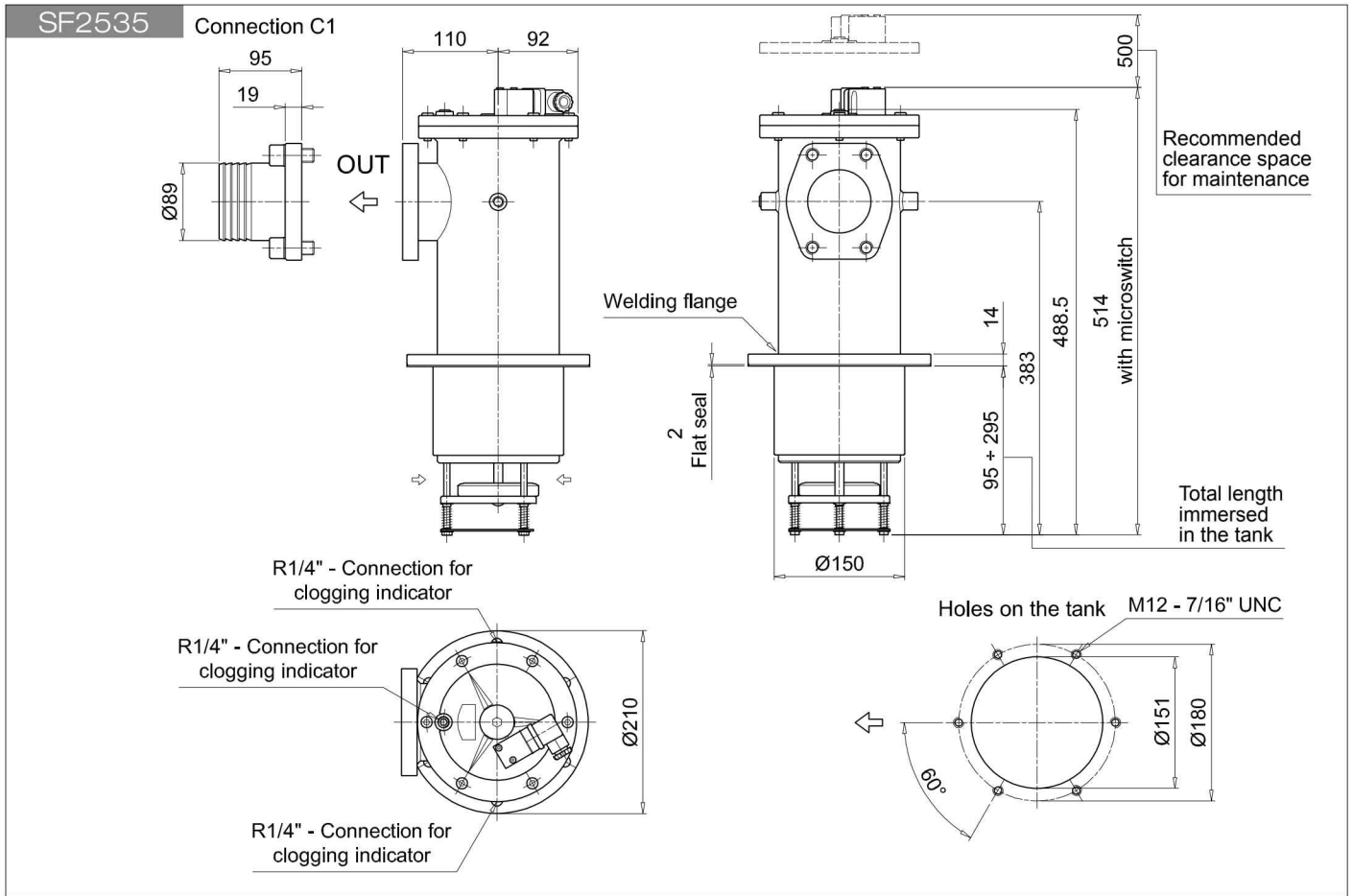

SPARE PARTS SF2 500

Order number for spare parts

SF2 500
SF2 501

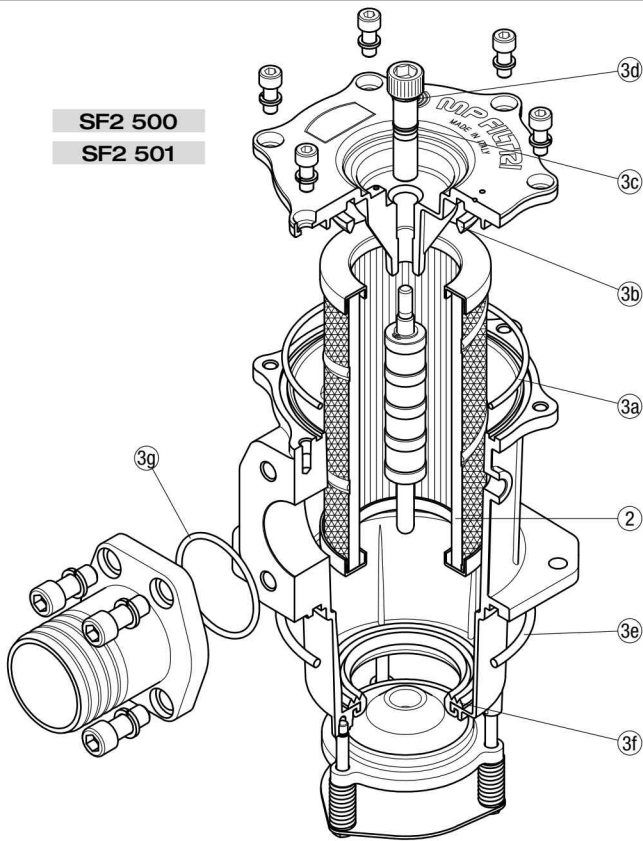

SF2 503
SF2 504

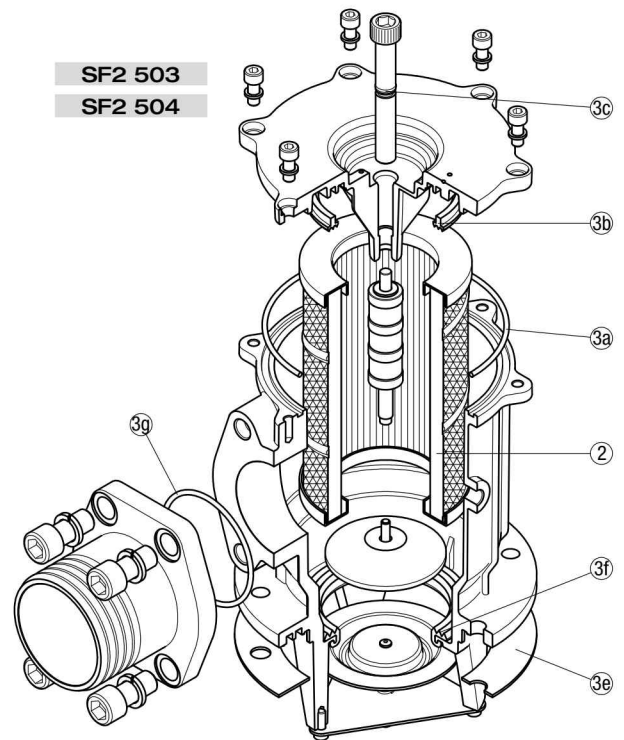

SF2 505
SF2 510
SF2 535
SF2 540

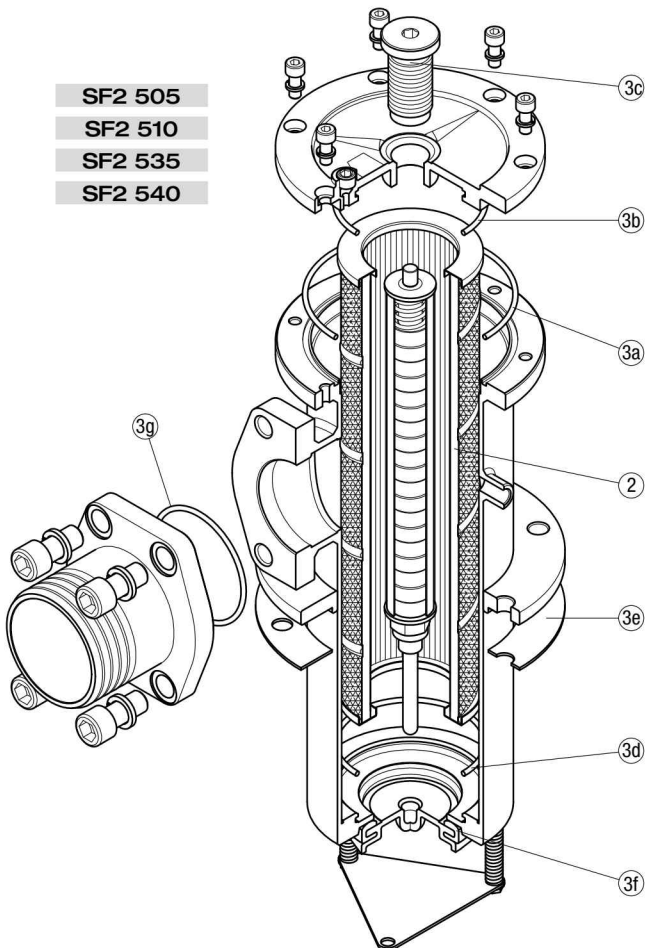

Item:	Q.ty: 1 pc.		
	2	3 (3a ÷ 3g)	
Filter series	Filter element	Seal Kit code number	
		NBR	FPM
SF2 500	See order table	02050141	02050142
SF2 501		02050143	02050144
SF2 503		02050070	02050071
SF2 504		02050072	02050073
SF2 505		02050043	02050044
SF2 510		02050045	02050046
SF2 535		02050051	02050052
SF2 540		02050053	02050054

Clogging indicators

Vacuum indicators

Introduction

Filter elements are efficient only if their Dirt Holding Capacity is fully exploited. This is achieved by using filter housings equipped with clogging indicators.

These devices trip when the clogging of the filter element causes an increase in pressure drop across the filter element.

The indicator is set to alarm before the element becomes fully clogged.

MP Filtri can supply vacuum indicators with a visual, electrical or both signals.

Suitable indicator types

VACUUM INDICATORS

Vacuum indicators are used on the Suction line to check the efficiency of the filter element. They measure the pressure downstream of the filter element.

Standard items are produced with R 1/4" EN 10226 connection.

Available products with R 1/8" EN 10226 to be fitted on MPS series.

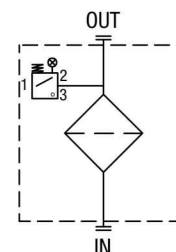
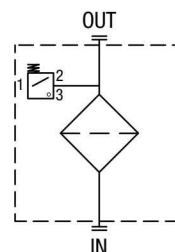
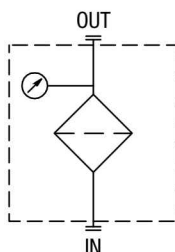

Quick reference guide

Filter series	Visual indicator	Electrical indicator	Electrical / Visual indicator
SF2 250 - 350	VVA16P01	VEA21AA50P01	VLA21AA51P01
SF2 500 - 501 - 503 - 504 - 505	VVR16P01		VLA21AA52P01
SF2 510 - 535 - 540			VLA21AA53P01 VLA21AA71P01

VACUUM INDICATORS

Dimensions

VE*50	
Electrical Vacuum Indicator	
R	Ordering code
EN 10226 - R1/4"	VE A 21 A A 50 P01

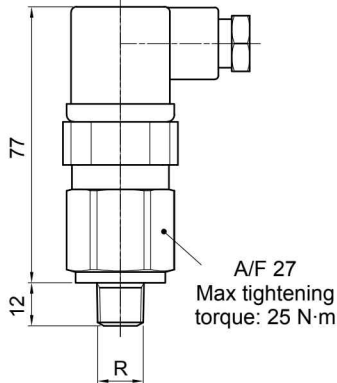

Hydraulic symbol

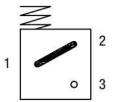

Electrical symbol

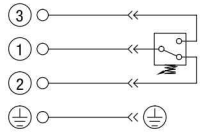

Materials

- Body: Brass
- Base: Black Nylon
- Contacts: Silver
- Seal: NBR

Technical data

- Vacuum setting: -0.21 bar ±10%
- Max working pressure: 10 bar
- Proof pressure: 15 bar
- Working temperature: From -25 °C to +80 °C
- Compatibility with fluids: Mineral oil, Synthetic fluids
HFA, HFB, HFC according to ISO 2943
- Degree of protection: IP65 according to EN 60529

Electrical data

- Electrical connection: EN 175301-803
- Resistive load: 5 A / 14 Vdc
4 A / 30 Vdc
5 A / 125 Vac
4 A / 250 Vac
- Available Atex product: II 1GD Ex ia IIC Tx Ex ia IIIC Tx°C X 
- CE certification

VL*51 - VL*52 - VL*53	
Electrical/Visual Vacuum Indicator	
R	Ordering code
EN 10226 - R1/4"	VL A 21 A A xx P01

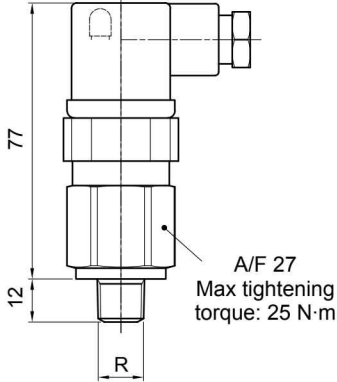

Hydraulic symbol

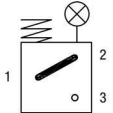

Electrical symbol

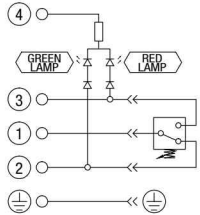

Materials

- Body: Brass
- Base: Transparent Nylon
- Contacts: Brass - Nylon
- Seal: NBR

Technical data

- Vacuum setting: -0.21 bar ±10%
- Max working pressure: 10 bar
- Proof pressure: 15 bar
- Working temperature: From -25 °C to +80 °C
- Compatibility with fluids: Mineral oil, Synthetic fluids
HFA, HFB, HFC according to ISO 2943
- Degree of protection: IP65 according to EN 60529

Electrical data

- Electrical connection: EN 175301-803
- Type: 51 52 53
- Lamps: 24 Vdc 110 Vdc 230 Vac
- Resistive load: 0.8 A / 24 Vdc 0.2 A / 115 Vdc 4 A / 230 Vac

VL*71	
Electrical/Visual Vacuum Indicator	
Connections	Indicator code
EN 10226 - R1/4"	VL A 21 A A 71 P01

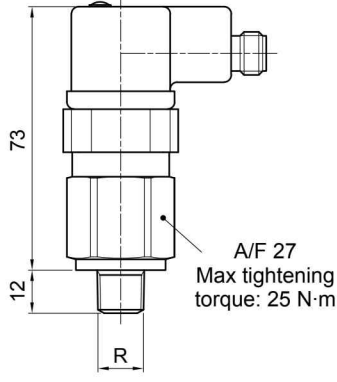

Hydraulic symbol

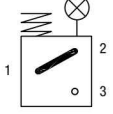

Electrical symbol

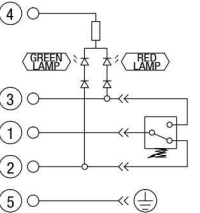

Materials

- Body: Brass
- Base: Black Nylon
- Contacts: Silver
- Seal: NBR

Technical data

- Vacuum setting: -0.21 bar ±10%
- Max working pressure: 10 bar
- Proof pressure: 15 bar
- Working temperature: From -25 °C to +80 °C
- Compatibility with fluids: Mineral oil, Synthetic fluids
HFA, HFB, HFC according to ISO 2943
- Degree of protection: IP65 according to EN 60529

Electrical data

- Electrical connection: IEC 61076-2-101 D (M12)
- Lamps: 24 Vdc
- Resistive load: 0.4 A / 24 Vdc

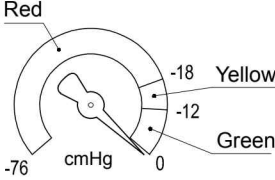
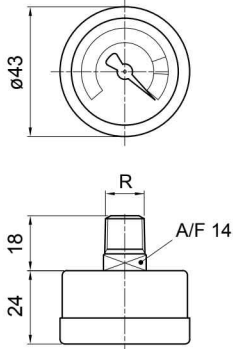
VVA		Hydraulic symbol	Materials							
Axial Vacuum Gauge										
R	Ordering code	Dial scale	<ul style="list-style-type: none"> - Case: Painted Steel - Window: Transparent plastic - Dial: Painted Steel - Pointer: Painted Aluminium - Pressure connection: Brass - Pressure element: Bourdon tube Cu-alloy soft soldered 							
EN 10226 - R1/4"	VV A 16 P01									
		<table border="1"> <thead> <tr> <th>[cmHg]</th> <th>[bar]</th> </tr> </thead> <tbody> <tr> <td>-12</td> <td>-0.16</td> </tr> <tr> <td>-18</td> <td>-0.24</td> </tr> <tr> <td>-76</td> <td>-1.01</td> </tr> </tbody> </table>	[cmHg]	[bar]	-12	-0.16	-18	-0.24	-76	-1.01
[cmHg]	[bar]									
-12	-0.16									
-18	-0.24									
-76	-1.01									

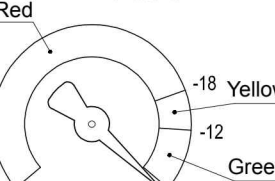
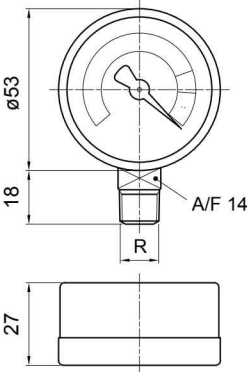
VVR		Hydraulic symbol	Materials							
Radial Vacuum Gauge										
R	Ordering code	Dial scale	<ul style="list-style-type: none"> - Case: Painted Steel - Window: Transparent plastic - Dial: Painted Steel - Pointer: Painted Aluminium - Pressure connection: Brass - Pressure element: Bourdon tube Cu-alloy soft soldered 							
EN 10226 - R1/4"	VV R 16 P01									
		<table border="1"> <thead> <tr> <th>[cmHg]</th> <th>[bar]</th> </tr> </thead> <tbody> <tr> <td>-12</td> <td>-0.16</td> </tr> <tr> <td>-18</td> <td>-0.24</td> </tr> <tr> <td>-76</td> <td>-1.01</td> </tr> </tbody> </table>	[cmHg]	[bar]	-12	-0.16	-18	-0.24	-76	-1.01
[cmHg]	[bar]									
-12	-0.16									
-18	-0.24									
-76	-1.01									

DESIGNATION & ORDERING CODE							
Series	Configuration example 1:	VE	A	21	A	A	50 P01
VE Electrical vacuum indicator	Configuration example 2:	VL	A	21	A	A	71 P01
VL Electrical/Visual vacuum indicator	Configuration example 3:	VV	R	16			P01
VV Vacuum gauge							
Type VE - VL	Type VV						
A Connection EN 10226 - R1/4"	A Axial connection EN 10226 - R1/4"						
	R Radial connection EN 10226 - R1/4"						
Vacuum setting	VE	VL	VV				
16 0.16 bar			•				
21 0.21 bar	•	•					
Seals	VE	VL	VV				
A NBR	•	•					
Thermostat	VE	VL	VV				
A Without	•	•					
Electrical connections	VE	VL	VV				
50 Connection EN 175301-803	•						
51 Connection EN 175301-803, transparent base with lamps 24 Vdc		•					
52 Connection EN 175301-803, transparent base with lamps 110 Vdc		•					
53 Connection EN 175301-803, transparent base with lamps 230 Vdc		•					
71 Connection IEC 61076-2-101 D (M12), black base with lamps 24 Vdc		•					
							Option
							P01 MP Filtri standard
							Pxx Customized

Filter elements are efficient only if their Dirt Holding Capacity is fully exploited. This is achieved by using filter housings equipped with clogging indicators.

These devices trip when the clogging of the filter element causes an increase in pressure drop across the filter element.

The indicator is set to alarm before the element becomes fully clogged.

MP Filtri can supply indicators of the following designs:

- **Vacuum switches and gauges**
- **Pressure switches and gauges**
- **Differential pressure indicators**

These type of devices can be provided with a visual, electrical or both signals.

Clogging Indicators



Clogging indicators



CLOGGING INDICATORS

Suitable indicator types

VACUUM INDICATORS

Vacuum indicators are used on the Suction line to check the efficiency of the filter element. They measure the pressure downstream of the filter element.

Standard items are produced with R 1/4" EN 10226 connection.

Available products with R 1/8" EN 10226 to be fitted on MPS series.

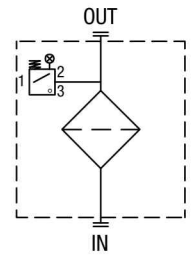
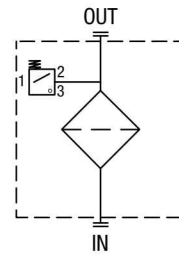
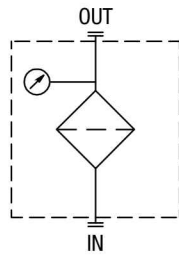

BAROMETRIC INDICATORS

Pressure indicators are used on the Return line to check the efficiency of the filter element. They measure the pressure upstream of the filter element.

Standard items are produced with R 1/8" EN 10226 connection.

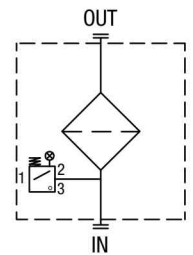
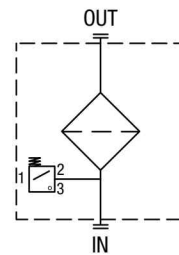
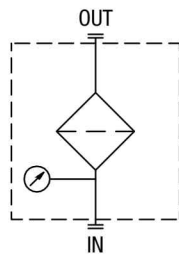

DIFFERENTIAL INDICATORS

Differential indicators are used on the Pressure line to check the efficiency of the filter element. They measure the pressure upstream and downstream of the filter element (differential pressure).

Standard items are produced with special connection G 1/2" size.

Also available in Stainless Steel models.

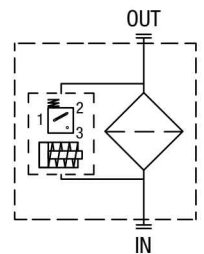
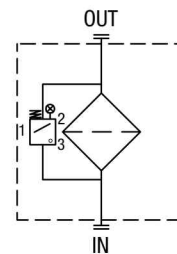
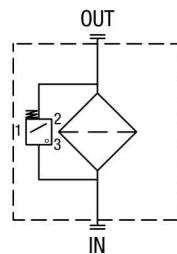
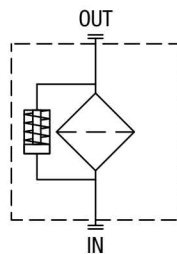

Filter family	Filter series	Visual indicator	Electrical indicator	Electrical / Visual indicator	Electronic indicator
SUCTION FILTERS	SF2 250 - 350 SF2 500 - 501 - 503 - 504 - 505 SF2 510 - 535 - 540	VVA16P01 VVR16P01	VEA21AA50P01	VLA21AA51P01 VLA21AA52P01 VLA21AA53P01 VLA21AA71P01	
RETURN FILTERS	MPFX-MPTX-MPF-MPT with bypass 1.75 bar MPH with bypass 1.75 bar	BVA14P01 BVR14P01 BVP20HP01 BVQ20HP01	BEA15HA50P01 BEM15HA41P01	BLA15HA51P01 BLA15HA52P01 BLA15HA53P01 BLA15HA71P01	
	MPFX-MPTX-MPF-MPT with bypass 3 bar MPH with bypass 2.5 bar FRI 255	BVA25P01 BVR25P01 BVP20HP01 BVQ20HP01	BEA20HA50P01 BEM20HA41P01	BLA20HA51P01 BLA20HA52P01 BLA20HA53P01 BLA20HA71P01	
	FRI 025 - 040 - 100 - 250 - 630 - 850	DVA20xP01 DVM20xP01	DEA20xA50P01 DEM20xAxxP01	DLA20xA51P01 DLA20xA52P01 DLA20xA71P01 DLE20xA50P01 DLE20xF50P01	DTA20xF70P01
RETURN / SUCTION FILTERS	Suction line MRSX 116 - 165 - 166	WVB16P01 VVS16P01	VEB21AA50P01	VLB21AA51P01 VLB21AA52P01 VLB21AA53P01 VLB21AA71P01	
	Return line MRSX 116 - 165 - 166 LMP 124	BVA25P01 BVR25P01 BVP20HP01 BVQ20HP01	BEA25HA50P01 BEM25HA41P01 BET25HF10P01 BET25HF30P01 BET25HF50P01	BLA25HA51P01 BLA25HA52P01 BLA25HA53P01 BLA25HA71P01	
SPIN-ON FILTERS	Suction line MPS 050 - 070 - 100 - 150 MPS 200 - 250 - 300 - 350	WVB16P01 VVS16P01	VEB21AA50P01	VLB21AA51P01 VLB21AA52P01 VLB21AA53P01 VLB21AA71P01	
	Return line MPS 050 - 070 - 100 - 150 MPS 200 - 250 - 300 - 350 MST 050 - 070 - 100 - 150	BVA14P01 BVR14P01 BVP20HP01 BVQ20HP01	BEA15HA50P01 BEM15HA41P01	BLA15HA51P01 BLA15HA52P01 BLA15HA53P01 BLA15HA71P01	
	In-line MPS 051 - 071 - 101 - 151 MPS 301 - 351 MSH 050 - 070 - 100 - 150	DVA12xP01 DVM12xP01	DEA12xA50P01 DEM12xAxxP01	DLA12xA51P01 DLA12xA52P01 DLA12xA71P01 DLE12xA50P01 DLE12xF50P01	
LOW & MEDIUM PRESSURE FILTERS	With bypass valve LMP 110 - 112 - 116 - 118 - 119 LMP 120 - 122 - 123 LMP 210 - 211 - LDP LMP 400 - 401 - 430 - 431 LMP 902 - 903 - 952 - 953 - 954 LMD 211 - 400 - 401 - 431 - 951 - LDD	DVA20xP01 DVM20xP01	DEA20xA50P01 DEM20xAxxP01	DLA20xA51P01 DLA20xA52P01 DLA20xA71P01 DLE20xA50P01 DLE20xF50P01	DTA20xF70P01
	Without bypass valve LMP 110 - 112 - 116 - 118 - 119 LMP 120 - 122 - 123 LMP 210 - 211 - LDP LMP 400 - 401 - 430 - 431 LMP 902 - 903 - 952 - 953 - 954 LMD 211 - 400 - 401 - 431 - 951 - LDD	DVA50xP01 DVM50xP01	DEA50xA50P01 DEM50xAxxP01	DLA50xA51P01 DLA50xA52P01 DLA50xA71P01 DLE50xA50P01 DLE50xF50P01	DTA50xF70P01
HIGH PRESSURE FILTERS	With bypass valve FMP 039 - 065 - 135 - 320 FHP 010 - 011 - 065 - 135 - 320 - 500 FMM 050 - FHA 051 FHM 006 - 007 - 010 - 050 - 065 - 135 - 320 - 500 FHB 050 - 135 - 320 FHF 325 FHD 021 - 051 - 326 - 333	DVA50xP01 DVM50xP01	DEA50xA50P01 DEM50xAxxP01	DLA50xA51P01 DLA50xA52P01 DLA50xA71P01 DLE50xA50P01 DLE50xF50P01	DTA50xF70P01
	Without bypass valve FMP 039 - 065 - 135 - 320 FHP 010 - 011 - 065 - 135 - 320 - 500 FMM 050 - FHA 051 FHM 006 - 007 - 010 - 050 - 065 - 135 - 320 - 500 FHB 050 - 135 - 320 FHF 325 FHD 021 - 051 - 326 - 333	DVA70xP01 DVM70xP01	DEA70xA50P01 DEM70xAxxP01	DLA70xA51P01 DLA70xA52P01 DLA70xA71P01 DLE70xA50P01 DLE70xF50P01	DTA70xF70P01
STAINLESS STEEL HIGH PRESSURE FILTERS	With bypass valve FZH 010 - 011 - 039 FZP 039 - 136 FZX 011 FZB 039 FZM 039 FZD 051	DVX50xP01 DVG50xP01	DEX50xA50P01	DLX50xA51P01 DLX50xA52P01	
	Without bypass valve FZH 010 - 011 - 039 FZP 039 - 136 FZB 039 FZM 039 FZD 010 - 021 - 051	DVX70xP01 DVG70xP01	DEX70xA50P01	DLX70xA51P01 DLX70xA52P01	

All data, details and words contained in this publication are provided for information purposes only.
MP Filters reserves the right to make modifications to the models and versions of the described products at any time
for both technical and / or commercial reasons.
The colors and the pictures of the products are purely indicative.
Any reproduction, partial or total, of this document is strictly forbidden.
All rights are strictly reserved.

Rev. 10-2017



The mark of
responsible forestry



WORLDWIDE NETWORK

HEADQUARTERS

MP Filtri S.p.A.
Via 1° Maggio, 3
20060 Pessano con Bornago
Milano - Italy

BRANCH OFFICES

MP Filtri U.K. Ltd.
Bourton Industrial Park
Bourton on the Water
GL54-2HQ Gloucestershire

MP Filtri Canada Inc.
8831 Keele Street
Concord, Ontario
L4K 2N1 - Canada

MP Filtri Germany GmbH
Hans-Wilhelmi-Straße
DE-66386 St. Ingbert

ITALFILTRI LLC
Russian Federation
Yurievsky Pereulok 13 a, Building 1
111020 Moscow - Russia

MP Filtri France SAS
Parc d'activités des Chanteraines
8 rue du Commandant d'Estienne d'Orves
Immeuble D3
92390 Villeneuve la Garenne

MP Filtri (Shanghai) Co., Ltd.
1280 Lianxi Road, Bld 8 - 2nd Floor
Shanghai - Pudong
201204 China

MP Filtri U.S.A. Inc.
2055 Quaker Pointe
PA 18951 Drive Quakertown

MP Filtri India Pvt. Ltd.
Plot-7F, Raj Pinnacle,
Beside RMZ Centennial
Brookefield Road, Whitefield
560048 Bangalore

PASSION TO PERFORM



mpfiltri.com